

F4200N ROBOT OPERATING MANUAL



15 Corporate Drive, Suite E - Wayne - NJ 07470
Tel: (973) 646-5044 E-mail: info@fisnar.com
www.fisnar.com

THIS PAGE INTENTIONALLY LEFT BLANK

TABLE OF CONTENTS

SECTION 1: INTRODUCTION	4
1. SAFETY PRECAUTIONS	5
2. PACKAGE CONTENTS	6
3. CONNECTOR AND SWITCH LOCATIONS	7
SECTION 2: SETUP	8
1. UNPACKING THE ROBOT	9
2. SETUP	9
SECTION 3: TEACHING OVERVIEW	10
1. TEACHING OVERVIEW	11
2. USING THE TEACH PENDANT	13
2.1 Key Selection	13
2.2 Key Assignments	14
2.3 Data Entry	15
2.4 Running a Program	15
3. POINT TYPE & FUNCTION SUMMARY	16
3.1 Point Menu (F1)	16
3.2 Menu 1 (F2)	18
3.3 Utility Menu (Within Menu1)	19
3.4 Menu 2 (F3)	20
3.5 Setup Menu (F4)	21
SECTION 4: PROGRAMMING EXAMPLE	23
1. PROGRAMMING EXAMPLE	24
2. GOOD PROGRAMMING PRACTICES	27
3. EDITING A PROGRAM	28
3.1 Changing a Point's XYZ location	28
3.2 Insert / Delete an Instruction	28
4. CHANGING THE PROGRAM NUMBER	29
5. CHANGING FROM TEACH MODE TO RUN MODE	29
SECTION 5: POINT TYPE & FUNCTION REFERENCE	30
1. F1 (POINT MENU)	31
1.1 Dispense Dot	31
1.2 Line Start	31
1.3 Line Passing	32
1.4 Circle	32
1.5 Arc Point	33
1.6 Line End	33
1.7 End Program	33
1.8 Dispense ON / OFF	34
1.9 GOTO Address	35
1.10 Step & Repeat X	35
1.11 Step & Repeat Y	40
1.12 Brush Area	41
1.13 Call Subroutine	48
1.14 Call Program	49
1.15 Set I/O	49
1.16 Wait Point	50
1.17 Stop Point	50
1.18 Home Point	50
1.19 Loop Address	50

1.20	Dummy Point	51
1.21	Initialize	51
1.22	Label	51
1.23	Display Counter	51
1.24	Loop Counter	51
1.25	Dispense Output Setup	52
2.	F2 (MENU 1)	53
2.1	Group Edit	53
2.2	Expand Step & Repeat	60
2.3	Program Name	61
2.4	Z-axis Limit (mm)	61
2.5	Initial Output Port	61
2.6	Debug Speed (mm/s)	62
2.7	Utility Menu	62
2.8	Jog Speed	62
2.9	Adjust Origin	62
2.10	Control by RS232	62
2.11	Resume	63
3.	UTILITY MENU (WITHIN MENU 1)	64
3.1	Program	64
3.2	Memory	64
3.3	Teach Pendant	65
3.4	Relocate Data	65
3.5	Lock or Unlock Program	67
3.6	Password Setup	67
3.7	Cycle Counter	67
3.8	Key Beep	68
3.9	Test Function	68
4.	F3 (MENU 2)	70
4.1	Numerical Move	70
4.2	Save Temp Point	70
4.3	Move To Temp Point	70
4.4	Undo Program	70
4.5	Redo Program	70
4.6	Debug Program	70
4.7	Move To Home Position	71
4.8	System Information	71
4.9	Execute Point	71
4.10	Program List	71
5.	F4 (SETUP MENU)	72
5.1	Line Speed	72
5.2	Line Dispense Setup	72
5.3	Point Dispense Setup	73
5.4	Dispense End Setup	73
5.5	Z Clearance	75
5.6	X/Y Move Speed	76
5.7	Z Move Speed	76
5.8	Home Position Setup	77
5.9	Adjust Position Setup	78
5.10	Retract Setup	80
5.11	Quickstep	82
5.12	Auto Purge Setup	83
5.13	ESTOP Output Status	83
5.14	Acceleration	84
5.15	Pause Status	84
SECTION 6: SAMPLE PROGRAMS		85
1.	DOTS, LINES AND ARCS – SAMPLE PROGRAM	86
2.	BRUSH AREA – SAMPLE PROGRAM	88
3.	STEP & REPEAT – SAMPLE PROGRAM	89
4.	INPUT / OUTPUT SIGNAL PROCESSING – SAMPLE PROGRAM	91

SECTION 7: ERROR MESSAGES AND SPECIFICATIONS.....93

1.	ERROR MESSAGES	94
1.1	Point Closed Error	94
1.2	Need Line Start Point.....	94
1.3	Need Step & Repeat	94
1.4	Unlock Program	94
1.5	Address Over Memory	95
1.6	Move Over Memory	95
1.7	System Error	95
2.	I/O SPECIFICATIONS.....	96
2.1	Dispenser Connector:.....	96
2.2	Ext. Control Connector:	97
2.3	Output Signals	98
2.4	Input Signals	99
2.5	Input / Output Schematic	100
2.6	Input / Output Power Specifications	100
2.7	Robot External I/O Card.....	101
3.	SYSTEM SPECIFICATIONS	102
4.	MACHINE DIMENSIONS	103
4.1	F4200N Dimensions	103
4.2	Work Table Dimensions.....	104

SECTION 8: MAINTENANCE AND PERIODIC INSPECTION.....105

1.	CHECK CYCLES AND METHODS	106
1.1	General Consideration	106
1.2	Check Cycles and Points.....	106
1.3	Check Methods.....	107
2.	GREASING PROCEDURE.....	108
2.1	Grease Type and Greasing Interval.....	108
2.2	Accessing Parts to be Greased	108







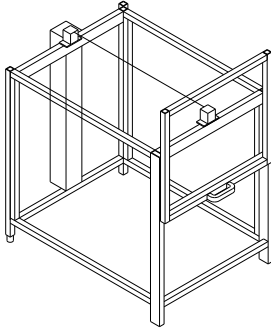

SECTION 1: Introduction

1. Safety Precautions

- 1.1 Make sure the robot is connected to a properly grounded power source before operating.
- 1.2 Keep away from any moving parts while the robot is running.
- 1.3 Loading and unloading of parts and material must only be done when the robot is at a complete stop.
- 1.4 Changing of fixtures or tooling must be done with the power source disconnected.
- 1.5 The F4200N robot should only be operated in an environment between 0 and 40 degrees Celsius with humidity of 20 to 95 percent and no visible condensation.
- 1.6 Do not store or setup the robot in an area where it is directly exposed to sunlight.
- 1.7 Do not operate the robot where electrical noise is present.
- 1.8 Only use a neutral chemical for cleaning the robot. Do not use alcohol, benzene or thinner as it may damage the paint on the robot.
- 1.9 Due to the electronic nature of this equipment and the potential for a spark or generation of heat, note that this equipment must **NOT** be used with any explosive material or in an explosive type environment.

2. Package Contents

In addition to this operating manual, the following *items* should be included with the robot:

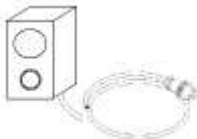
 <p>Main Unit (F4200N)</p>	 <p>Enclosure (CE Units Only – Not Included)</p>
 <p>Teach Pendant</p>	 <p>Barrel Holder</p>
 <p>Spare Screws and Hex Key</p>	 <p>Teach Pendant Cable</p>
 <p>Power Cord</p>	 <p>Dispenser Cable</p>
 <p>RS232 Cable and Null Modem Adapter (optional)</p>	 <p>Start / Stop Box (optional)</p>
	<ul style="list-style-type: none"> - External Control Connector - Spare Control Connector - Barrel and Air Line

3. Connector and Switch Locations

Left side view

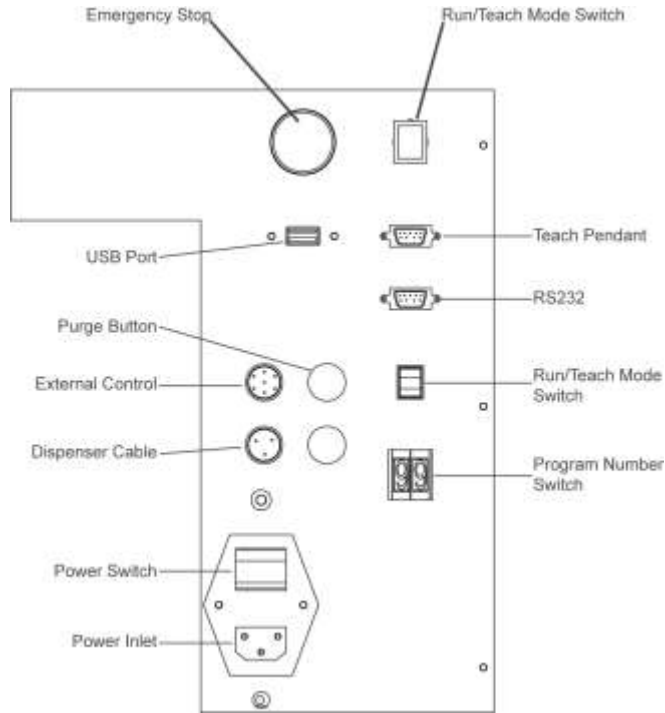

Right side view

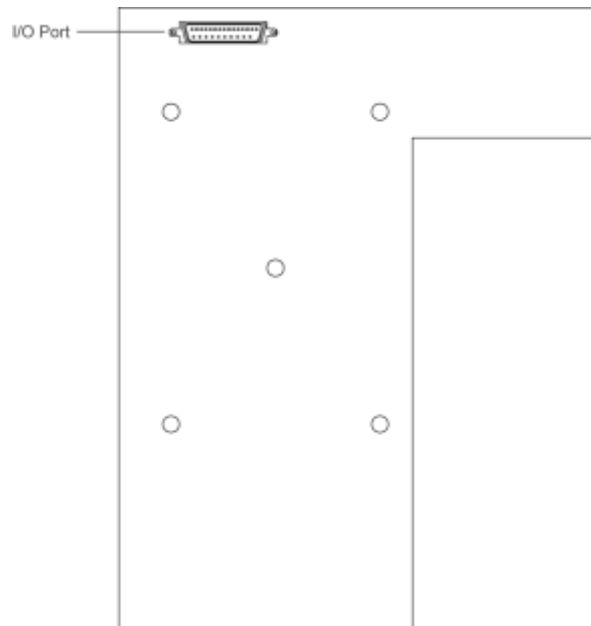

SECTION 2: Setup

1. Unpacking the Robot

- Always lift the robot from its base. Never lift the robot from the cross member.
- Remove all accessories from the shipping package before attempting to remove the robot.
- Place the robot on a stable workbench before operating.
- If possible, do not discard the packing material as these items may be needed if the robot is shipped or moved in the future.

2. Setup

F4200 robot is available with different configurations. The setup of each machine with its accessories will depend on the customer's application.

If an enclosure is NOT being used, the enclosure door switch may be bypassed by connecting the plug labeled SHORTED (included in the robot accessories box) to the External Control Connector.

- 2.1. When using an enclosure or light curtain connect the external start / stop box and enclosure door switch or light curtain to the External Control connector on the main unit. For further information, see **SECTION 7.2.2: External Control Connector**
- 2.2. Connect one end of the Teach Pendant cable to the Teach Pendant and the other end to the Teach Pendant connection on the robot.
- 2.3. Connect the power cord of the F4200N robot to the power socket on the robot. Be sure to use the correct power cord and power source for the robot model you are using (110 V or 220 V).
- 2.4. Tie back all cables and air lines so that they will not interfere with the robot's motion when the robot is operating. Be sure that the cables and air lines do not restrict the motion of the robot's head and the robot's table and make sure that they cannot become jammed as the robot moves through the work area.

SECTION 3: Teaching Overview

1. Teaching Overview

A program consists of a series of instructions stored in the main memory unit. Each instruction is stored in a numbered memory address. A memory address may record a point location with an X, Y, and Z-axis value and point type or it may store an instruction, which sets a parameter, such as a dispensing time or line speed.

When the program is executed, the robot will go through each memory address in sequence and execute the instruction found there. If the memory address contains a point location, the robot will move the X, Y, and Z axes to that location. Depending on the type of point registered at that location, the robot may also perform other functions, such as turn the dispenser on or off.

The most commonly used point types are Dispense Dot, Line Start, Line Passing, Arc Point, and Line End.

To program the robot to dispense a 'dot' of material, the dispensing tip must be jogged to the desired XYZ location, then that location is registered as a DISPENSE DOT point type by pressing the appropriate keys on the Teach Pendant.

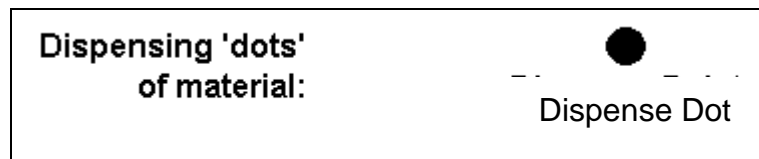

To program the robot to dispense a bead of material along a linear path, the XYZ location of the start of the line is registered as a LINE START point type. The locations where the tip changes direction are registered as LINE PASSING points. The end of the line is registered as a LINE END point:

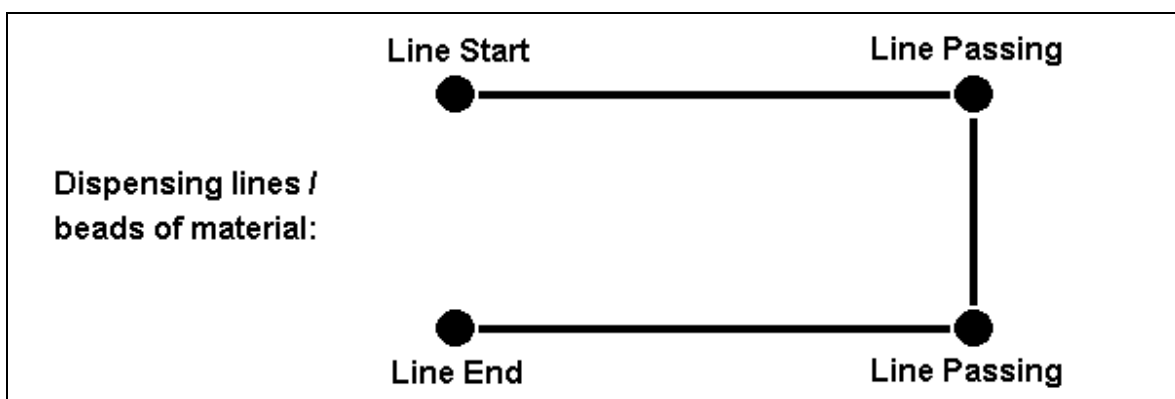

To dispense a bead of material in an arc, the XYZ location of the start of the line is registered as a LINE START point type. The high point of the arc is registered as an ARC POINT. The end of the arc is registered as a LINE END point:

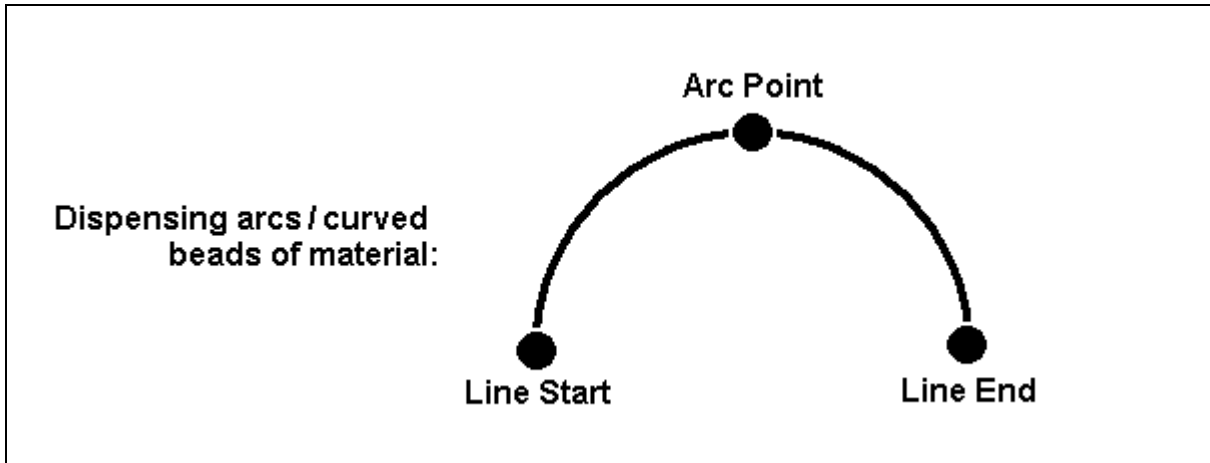

Lines and arcs can also be combined to dispense a bead of material along a complex path:

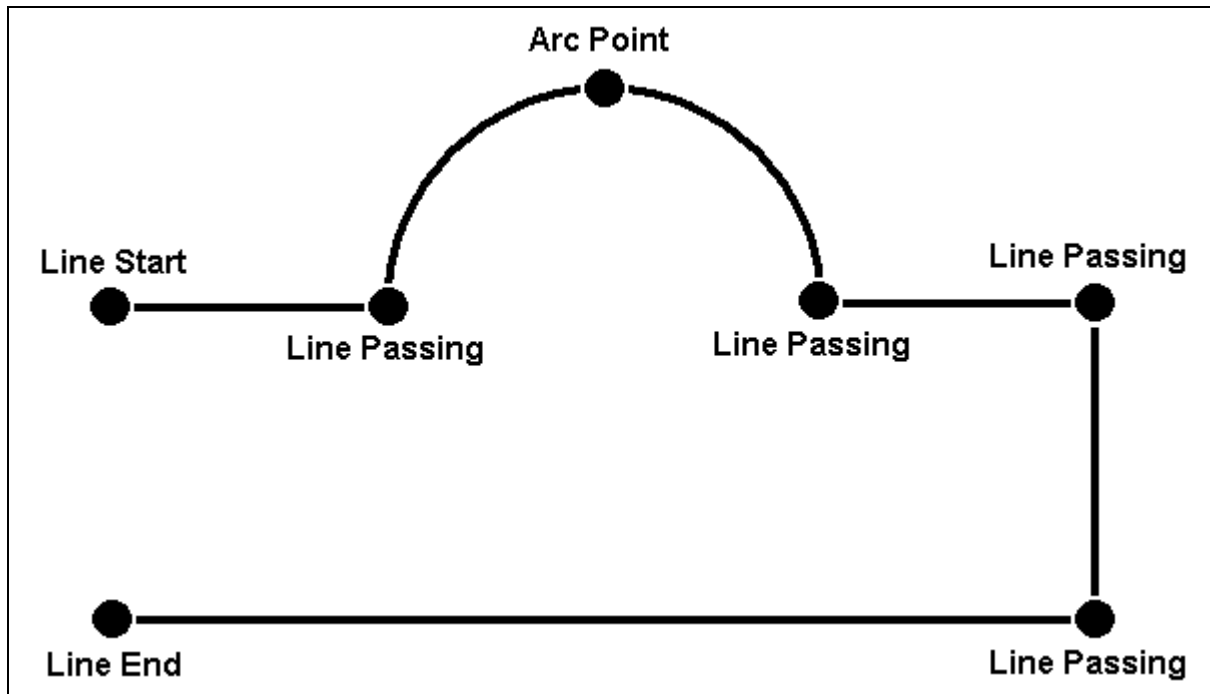

Once the required point locations for your program have been taught, the teach pendant is no longer required. The unit can be switched to RUN mode and operated using the buttons and switches on the main unit control panel.

2. Using the Teach Pendant

The teach pendant enables the user to jog the robot and input program data.

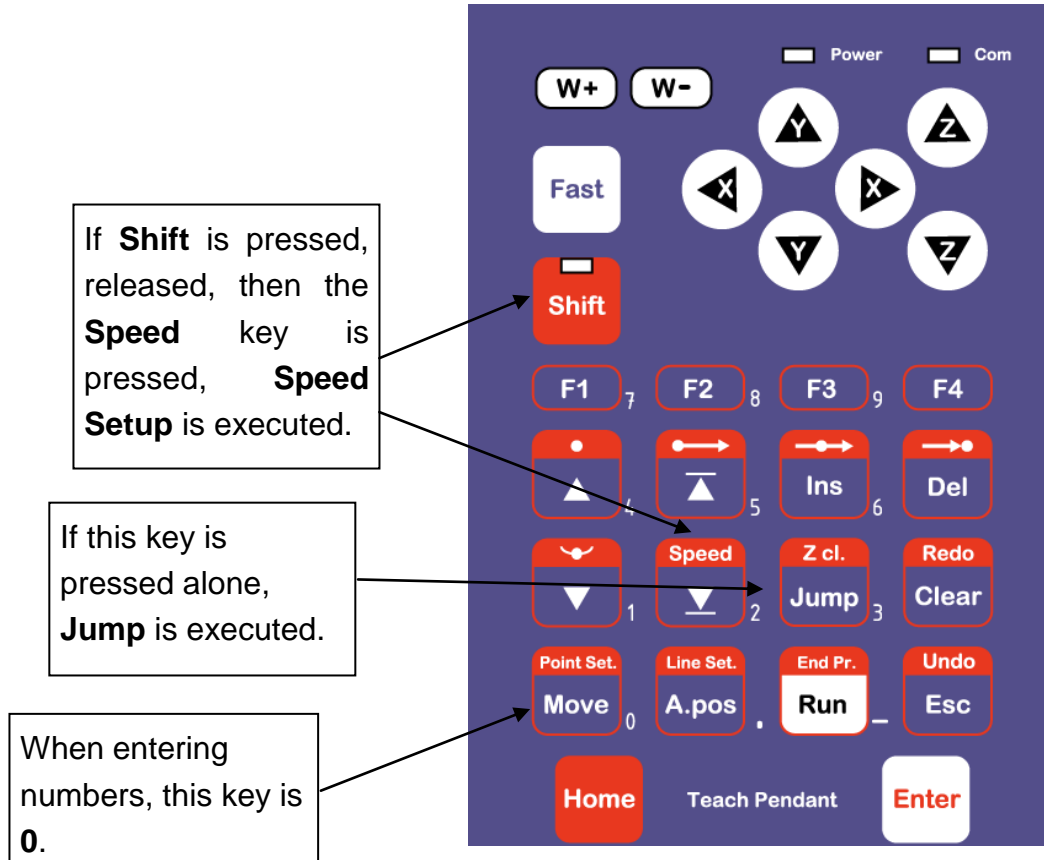

2.1 Key Selection





There are several functions assigned to most keys on the Teach pendant. When a key is pressed alone, the function shown in the blue colored area on the key is executed. For example, **Ins**, **Del**, **Jump**, **Clear** and **Esc** are the default key functions, which are executed when that key is pressed alone.

To access the function shown in the blue colored area at the top of a key, press and release the **Shift** key first (the LED on the **Shift** key will be flashing), then press the desired key. For example, to select the **Speed** function, press and release **Shift**, then press the **Speed** key.







When a number is required, the teach pendant will automatically switch to numeric entry mode. The number represented by each key is shown in the lower right corner of the key.

2.2 Key Assignments















Menu Keys

	Opens the Point Menu.		Opens Menu 1.		Opens Menu 2.		Opens the Setup Menu.
---	-----------------------	---	---------------	---	---------------	---	-----------------------

























Jog Keys

	Jogs the Y-axis in the forward direction.		Jogs the X-axis in the right direction.		Jogs the Z-axis DOWN.
	Jogs the Y-axis in the backward direction.		Jogs the X-axis in the left direction.		Jogs the Z-axis UP.
	<p>Accelerates jog speed – used with X+, X-, Y+, Y-, Z Up, Z Down</p> <p>If the FAST button is pressed and held first, then one of the jog buttons is pressed, the axis will be jogged at the maximum jog speed.</p> <p>If one of the jog buttons is pressed first, then the FAST button is pressed, the jog motion will accelerate.</p> <p>If the FAST button is released, the jog motion will decelerate.</p>				

Key Assignments

	Moves backward (1) memory address.		Changes the display to memory address number 1.		Inserts a memory address before the current address.
	Moves forward (1) memory address.		Changes the display to the last memory address used in the program.		Deletes the current memory address.
	Moves the tip to the point location currently in the display.		Jumps to a specified memory address		Clears / erases the numeric value currently shown in the display.
	Adjusts the tips position after a barrel change		To run the program		Homes the robot. Initializes all axes and moves the head to the position (0, 0, 0).
	(Enter)—used to confirm data entries. Opens the Point registration menu.		<p>If pressed once, clears the current numeric value.</p> <p>If pressed twice, cancels the current function.</p> <p>If a program is running, cancels the running program.</p> <p>Changes from Point List display mode to Single Point display when teaching point data.</p>		

Key Functions

 → 	Registers a DISPENSE DOT point.	 → 	Registers a LINE START point.
 → 	Registers a LINE PASSING point.	 → 	Registers a LINE END point.
 → 	Registers an ARC POINT.	 → 	Registers a Line Speed command.
 → 	Registers a Point Dispense Setup command.	 → 	Registers a Line Dispense Setup command.
 → 	Registers the End Program command.	 → 	Redo
 → 	Undo	 → 	Registers a Z Clearance command.

2.3 Data Entry

When a number is required, the teach pendant will automatically switch to numeric entry mode. The number represented by each key is shown in the lower right corner of the key.

2.4 Running a Program

Press the  key to run the program.

3. Point Type & Function Summary

3.1 Point Menu (F1)

Below is a list of Point Types, which are found under the **F1** key (**Point** menu):

Function	Description
Dispense Dot	Registers the current XYZ location as a Dispense point for dot dispensing.
Line Start	Registers the current XYZ location as a Line Start point for line dispensing.
Line Passing	Registers the current XYZ location as a Line Passing point. This is a location on the line where the tip changes direction, such as at the corner on a rectangle.
Circle	Registers a circle with the circle center at the current XYZ location. The display will prompt the user for the circle diameter.
Arc Point	Registers the current XYZ location as an Arc point. Arc points are used to dispense material in an arc or circle.
Line End	Registers the current XYZ location as a Line End point.
End Program	Registers the current memory address as the end of the program.
Dispense On / Off	Registers an instruction which turns the dispenser on or off at the current XYZ location.
GOTO Address	Causes the program to jump to the specified memory address.
Step & Repeat	Registers an instruction that will re-run a selected group of memory addresses, stepping by a user-defined distance in the X or Y-axis after each copy. The matrix of parts is defined by specifying the number of rows, the number of columns, the X offset and the Y offset. Step & Repeat X indicates that the robot will give priority to the X-axis, running the parts along the X-axis first. Step & Repeat Y indicates that the robot will give priority to the Y-axis, running the parts along the Y-axis first.
Brush Area	Causes the tip to 'paint' the defined area. The painted area can be in the form of a rectangle or a circle / spiral.
Call Subroutine	Causes the machine to jump to a specified memory address and execute the instructions found there. When the end program instruction is reached, program execution will continue at address just after the call Subroutine instruction.

Function	Description
Call Program	Jumps to the specified program number from within the current program.
Set I/O	Registers an instruction, which either sets the value of an output signal or checks the status of an input signal.
Wait Point	After executing the current point (Line start, passing, etc) the robot will wait a specified amount of time before moving to the next command.
Stop Point	After executing the current point (Line start, passing, etc), the robot will wait until the start button is pressed before moving to the next command.
Home Point	Registers an instruction to 'home' all axes, sending them to the home position. See the Setup Menu for instructions on changing the location of the home position.
Loop Address	Causes the program to execute a group of memory addresses a user-specified number of times.
Dummy Point	Registers the current XYZ location as a Dummy point. The tip will simply pass through this point. Useful for avoiding obstacles on the work piece.
Initialize	Registers an Initialize point. Causes the robot to perform a mechanical initialization.
Label	Registers a label that can be used as a reference when used with the GOTO address, Loop address, Set I/O, Step & repeat X, Step & repeat Y and Call Subroutine commands.
Display Counter	Shows a counter at the bottom of the teach pendant screen while a program is running.
Loop Counter	The <i>Loop Counter</i> either clears or keeps the current tally of the counter when an I/O signal is received. The tally is cumulatively added to the current count on the display counter.
Line end 1	Registers the current memory address as the end of the "stadium" path setting.
Dispense Output Setup	Defines the dispense output port number for line dispense setup.

3.2 Menu 1 (F2)

Below is a list of functions, which are found under the **Menu 1** key:

<i>Function</i>	<i>Description</i>
Group Edit	Allows a function to be applied to a user-defined group of memory addresses. Functions include copy, delete, move, multiply line speed, multiply dispense times, apply X Offset, apply Y Offset, apply Z Offset
Expand Step & Repeat	Expands the memory address locations which would be performed at a Step & Repeat instruction so individual memory addresses of the repeated instructions can be edited
Program Name	Allows the user to register a name for the current program number
Z-axis Limit (mm)	Sets the MAXIMUM Z-axis value (the lowest tip position). Once the Z-axis limit is set, the robot will prevent the tip from jogging below the set location.
Initial Output Port	Sets the status of the output signals when the machine is initialized
Debug Speed	Sets the speed used when running in Debug mode.
Utility Menu	Opens the Utility Menu. See Section 3 Chapter 3.3.
Jog Speed	Allows the user to set the tip jog speed for teach mode: Low, Middle or High jog speed can be selected.
Adjust Position	See Section 3 Chapter 2.9 "Adjust Position Setup"
Control by RS232	Allows the robot to be controlled via the RS232 port
Resume	Determines if a program will restart from point #1 or the point at which it was interrupted if a program is stopped by an emergency stop or the enclosure door switch open signal.

3.3 Utility Menu (Within Menu1)

Below is a list of functions, which are found under **Menu 1 (F2) -> Utility Menu:**

Function	Description
Program	Opens the Program utility menu. Allows programs to be copied, backed up, restored, or cleared.
Memory	Opens the Memory utility menu. Allows the robot memory to be backed up, restored, or cleared.
Teach Pendant	Opens the Teach Pendant utility menu. Allows the current program to be copied to the Teach Pendant for transferring to another robot.
Relocate Data	Allows the position of a program to be corrected using two reference points. Corrects for X offset, Y offset and angle of rotation.
Lock Program	Locks or unlocks a program to enable or disable program editing
Cycle Counter	Allows the operator to set a number to the program cycle to run the program a number of times.
Password Setup	Allows the password to be set or reset for the current program. Protects the program from unauthorized editing.
Key Beep	Enabling Key Beep to produce a beep every time a key in the Teach Pendant is touched.
Test Function	Testing the Robot Sensor, Panel Connector, Input Output signal, Teach Pendant and Motor.

3.4 Menu 2 (F3)

Below is a list of functions, which are found under the **F3** key:

Function	Description
Numerical Move	Allows the tip to be positioned numerically by entering a number for the X, Y and Z values.
Save Temp Point	Saves the current XYZ position in a temporary memory area numbered 1 – 9.
Move To Temp Point	Retrieves a XYZ position, which was stored with Save Temp Point.
Undo Program	Cancels the last change to the program. Returns to the program state prior to the last change.
Redo Program	Restores the last change to the program, which was canceled with Undo.
Debug Program	Runs the program in Debug mode starting at the current point location.
Move To Home Position	Causes the tip to move to the home position. The default home position is X=0, Y=0, Z=0
System Information	Displays system information, including software version number, work area size and control board version
Execute Point	Runs a selected command.
Program List	Allows the operator to see all programs in the memory.

3.5 Setup Menu (F4)

Below is a list of functions, which are found under the **F4** key (**Setup** menu):

Function	Description
Line Speed	Registers the LINE SPEED used for all lines from the current memory address forward until another Line Speed instruction is found.
Line Dispense Setup	Registers the LINE DISPENSE SETUP values which sets dispensing wait time at the start of lines ('head' time), wait time at the passing points ('Node' time) and waiting time at the end of lines ('tail' time). The registered values will be used from the current memory address forward until another Line Dispense Setup instruction is found.
Point Dispense Setup	Registers POINT DISPENSE SETUP values, which sets dispensing time and waiting time at the end of dispensing ('tail' time) for dots. The registered values will be used from the current memory address forward until another POINT DISPENSE SETUP instruction is found.
Dispense End Setup	Registers the height and speed the tip should raise at the end of dispensing. The registered values will be used from the current memory address forward until another DISPENSE END SETUP instruction is found.
Z Clearance	Registers the addition distance the tip should rise, beyond the height set in Dispense End Setup, to allow obstacles to be cleared as the tip moves from one figure to another. Values will be used until another Z Clearance instruction is found.
XY Move Speed	Sets the movement speed of the X and Y axes when moving from one figure to another in the program
Z Move Speed	Sets the movement speed of the Z-axis when moving from one figure to another in the program
Home Position Setup	Changes the position the robot moves to at the end of a program cycle.

<i>Function</i>	<i>Description</i>
Adjust Position Setup	Registers the current XYZ location as the Adjust Position. This reference point can later be used to correct the program location after the dispensing tip has been changed.
Retract Setup	Registers Retract values at the current XYZ location. Retract causes the tip to move up and back over the dispensed bead after line dispensing.
Quickstep	Causes the robot to move very fast from one point to another reducing the time of the dispensing cycle.
Auto Purge Setup	Automatically purges the system at the end of the program.
ESTOP Output Status	After receiving the emergency stop signal, ESTOP Output Status can modify the status of all the outputs or leave them as before receiving the emergency signal.
Acceleration	Parameter that controls the robot's acceleration
Pause Status	Sets the position to which the tip moves after pressing the Start button. The tip can go to the Home position or will stay at the position where the Start button was pressed.
Language	Opens MENU for selecting the Language
Jog Speed	Allows the user to set the tip jog speed for teach mode: Low, Middle or High jog speed can be selected.
Adjust Position	See Section 3 Chapter 2.9 "Adjust Position Setup"
Quick Step Path	Allows the tip to move faster when dispensing.
USB Up/Down Load	Allows the operator to upload or download program/programs and software updates.
Circle Delay Time	Circle Delay Time allows the robot to stop at the end of a circle and allow excess material to be removed before the robot carries to the next point.

SECTION 4: Programming Example

1. Programming Example

To help you become familiar with programming the robot, please follow the instructions below to create a program, which dispenses in the following pattern:

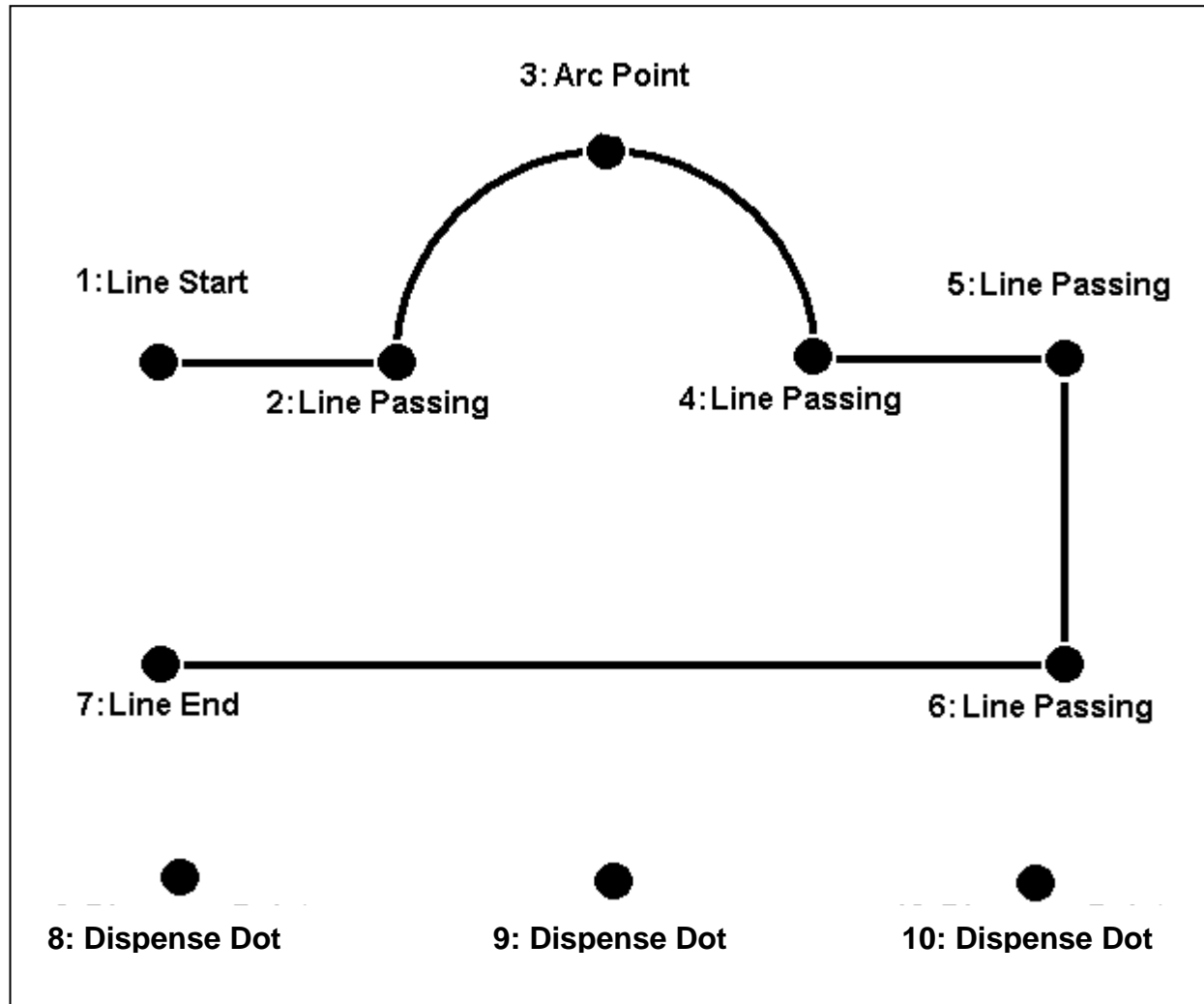

Notes:

- We will create the above program in program # 10.
- We will use a line speed of 40 mm / second for the lines and arcs in the program
- For dots, we will use a dispensing time of 0.50 seconds and a waiting time of 0.1 seconds after dispensing

	<i>Instruction</i>	<i>Display Shows</i>
1	Follow the instructions found in SECTION 2:2. Setup to setup the robot.	
2	Select program 10 using the program number selection switches on the main unit control panel. Turn the power on.	<pre>[MACHINE HOME] +-----+ START/HOME +-----+</pre>
3	Press the START button. The robot will move to the home position.	<pre>ADDR:1 PROG:10 EMPTY X:0.00 Y:0.00 Z:0.00</pre>
4	Press the Setup key, then 1 to select Line Speed to register a line speed of 40 mm/second at memory address number 1.	<pre>Line Speed Setup ----- Speed: unit: mm/sec</pre>
5	The robot is now waiting for the speed to be registered. Press 40 then ENTER to register a speed of 40 mm / second.	<pre>ADDR:2 PROG:10 EMPTY</pre>
6	<p>The display shows we are at memory address 2 and that it is empty.</p> <p>Jog the dispensing tip to the first location in the diagram above (1: Line Start).</p> <p>To jog the X and Y-axes, press the arrow keys X←, →X, Y↑ and Y↓. To jog the Z-axis, press the Z↑ and Z↓ keys.</p> <p>Press and hold the FAST key to jog fast. See <i>Error! Reference source not found. Jogging</i> for more information.</p>	
7	Once the tip is at the correct X, Y, Z location for the first point (1: Line Start), press the ENTER key, then 2 to register the location as a Line Start point.	<pre>ADDR:3 PROG:10 EMPTY</pre>
8	<p>The display will show we are at memory address 3 and it is empty. Jog the tip to the X, Y, Z location of the second point (2: Line Passing).</p> <p>When the location is correct, press the ENTER key, then 3 to register the location as a Line Passing point.</p>	<pre>ADDR:4 PROG:10 EMPTY</pre>

	<i>Instruction</i>	<i>Display Shows</i>
9	Now jog the tip to the location of the third point (3: Arc Point). When the location is correct, press the ENTER key, then 5 to register the location as an Arc point.	ADDR:5 PROG:10 EMPTY
10	Jog the tip to the location of the fourth point (4: Line Passing). When the location is correct, press the ENTER key, then 3 key to register the location as a Line Passing point.	ADDR:6 PROG:10 EMPTY
11	Jog the tip to the location of the fifth point (5: Line Passing). When the location is correct, press the ENTER key, then 3 to register the location as a Line Passing point.	ADDR:7 PROG:10 EMPTY
12	Jog the tip to the location of the sixth point (6: Line Passing). When the location is correct, press the ENTER key, then 3 to register the location as a Line Passing point.	ADDR:8 PROG:10 EMPTY
13	Jog the tip to the location of the seventh point (7: Line End). When the location is correct, press the ENTER key, then 6 to register the location as a Line End point.	ADDR:9 PROG:10 EMPTY
14	The line is now complete. The next step is to register the dispense settings for the dots. Press the SETUP key, then 3 to register the dot dispensing time.	Point Dispense Setup ----- Dis. Time: Tail Time: unit: sec
15	Type 0.5 to register a dispensing time of 0.5 seconds, and then press ENTER . Type 0.1 to register a waiting time after dispensing of 0.1 seconds, and then press ENTER .	ADDR:10 PROG:10 EMPTY
16	Jog the tip to the location of first dispense dot (8: Dispense Dot). When the location is correct, press the ENTER key, then 1 to register the location as a Dispense Dot.	ADDR:11 PROG:10 EMPTY
17	Jog the tip to the location of second dispense dot (9: Dispense Dot). When the location is correct, press the ENTER key, then 1 to register the location as a Dispense Dot.	ADDR:12 PROG:10 EMPTY
18	Jog the tip to the location of third dispense dot (10: Dispense Dot). When the location is correct, press the ENTER key, then 1 to register the location as a Dispense Dot.	ADDR:13 PROG:10 EMPTY
19	The program is now complete. Press ENTER , then 7 to register address 13 as the END of the program.	ADDR:14 PROG:10 EMPTY
20	To run the program, press the RUN key.	

2. Good Programming Practices

It is recommended to register the setup commands at the beginning of every program.

The following setup commands are the most commonly used:

- Dispense End Setup
- Point Dispense Setup
- Line Dispense Setup
- Line Speed
- Z Clearance
- Retract Setup
- Adjust Position Setup

For a complete list and description of all the different setup commands, refer to **SECTION 3:4.2 F4 (Setup Menu)** and **SECTION 5:2 Setup Menu**.

3. Editing a Program

You can move through the instructions in an existing program by using the following keys:

Key	Function
+1	Moves forward (1) memory address
-1	Moves backward (1) memory address
FIRST	Moves to the first memory address in the program
END	Moves to the last programmed memory address in the program
+10	Jumps forward (10) memory addresses
-10	Jumps backward (10) memory addresses
MOVE	Moves the tip to the XYZ point location of the selected point
JUMP	Jumps to display the specified memory address

3.1 Changing a Point's XYZ location

To change the XYZ location of a point, press the **+1** or **-1** key until the point you want to change is shown in the display.

You can confirm that the correct point is in the display by pressing the **MOVE** key. This will cause the tip to move to the XYZ position shown in the display.

Now use the jog keys (**X**←, **→** **X**, **Y**↑ and **Y**↓) and the **Z**↑ / **Z**↓ keys to jog the tip to the new location.

Once the location is correct, simply re-register the point as you did when it was first taught, by pressing the **ENTER** key and selecting the point type. The point will be re-registered at the new location.

3.2 Insert / Delete an Instruction

- To insert an instruction, press the **INS** key. The point currently shown in the display will be moved forward one memory address. A new, empty memory address will be inserted at the current memory address.
- To delete the instruction currently shown in the display, press the **DEL** key, and then press the F1 (Yes) key.

4. Changing the Program Number

The program number is selected by the program number selection switches on the main unit's control panel.



Press the + and – buttons to select the program number.

Note: Program 99 is designed for “autorun” on Run mode. When starting the robot with this program, the robot starts automatically without pressing the Start/Home key for initialization.

5. Changing from Teach Mode to Run Mode

To change from Teach mode to Run mode, change the position of the mode switch on the main unit's control panel.

When the machine is in Run mode, the teaching box (teach pendant) is not required. Programs can be selected and run using the switches on the front control panel of the main unit.

SECTION 5: Point Type & Function Reference

1. F1 (Point Menu)

Below is a list of functions which are found under the **ENTER** key. These functions are 'point-type' functions, meaning that the values applied will occupy one memory address.

Please see **SECTION 6: Sample Programs** for additional programming examples.

1.1 Dispense Dot

Registers the current XYZ location as a dispense point for dot dispensing.

The dispense time and wait time must be set in a previous memory address by registering a **Point Dispense Setup** instruction.

The upward motion of the tip after dispensing can be controlled by registering a **Dispense End Setup** instruction and / or a **Z Clearance** instruction in a previous memory address.

Dispense End Setup and **Z Clearance** instructions are registered using the **SETUP** key.

See also **SECTION 5:5.3 Point Dispense Setup**, **SECTION 5:5.4 Dispense End Setup** and **SECTION 5:5.5 Z Clearance**.

1.2 Line Start

Registers the current XYZ location as a Line Start point for line dispensing.

The line speed must be set in a previous memory address by registering a **Line Speed** instruction using the **SETUP** key.

Dispense delay times used at Line Start and Line End points can be controlled by registering a **Line Dispense Setup** instruction in a previous memory address. The **Line Dispense Setup** instruction is registered by pressing the **SETUP** key.

See also **SECTION 5:5.1 Line Speed** and **SECTION 5:5.2 Line Dispense Setup**.

1.3 *Line Passing*

Registers the current XYZ location as a Line Passing point. This is a location on the line where the tip changes direction, such as at the corner on a rectangle.

Also use a Line passing point before and after an Arc Point instruction.

1.4 *Circle*

Registers a circle, where the circle's center is at the current XYZ location. To register a circle, jog the tip to the circle's center and press **ENTER**, and then press the key 4 (for circle). The display will prompt you to type the following data:

Diameter: Type the diameter of the circle and press **ENTER**.

Over Angle: (The value is from 1~360). After dispensing the circle, while going through an extra part of the circle defined by the Over Angle, the dispenser will be turned OFF.

Z Lift: 1. Yes 2. No

Selection: If you want the Z-axis (tip) to lift while going through the Over Angle, you must select 1. Otherwise: select 2.

The speed must be set in a previous memory address by registering a **Line Speed** instruction using the **SETUP** key.

Dispense delay times used at the start of the circle and at the end of the circle can be controlled by registering a **Line Dispense Setup** instruction in a previous memory address. The **Line Dispense Setup** instruction is registered by pressing the **SETUP** key.

See also **SECTION 5:5.1 Line Speed** and **SECTION 5:5.2 Line Dispense Setup**.

The upward motion of the tip after dispensing can be controlled by registering a **Dispense End Setup** instruction and / or a **Z Clearance** instruction in a previous memory address.

Dispense End Setup and **Z Clearance** instructions are registered using the **SETUP** key.

See also **SECTION 5:5.4 Dispense End Setup** and **SECTION 5:5.5 Z Clearance**.

1.5 Arc Point

Registers the current XYZ location as an Arc Point. Arc points are used to dispense material along an arc or circular path.

See SECTION 4: *Programming Example*, for an example of the use of an Arc point.

1.6 Line End

Registers the current XYZ location as a Line End point.

The dispense delay time used at the end of the line can be controlled by registering a *Line Dispense Setup* instruction in a previous memory address. The *Line Dispense Setup* instruction is registered by pressing the **SETUP** key.

See also *SECTION 5:5.2 Line Dispense Setup*.

The upward motion of the tip after dispensing can be controlled by registering a *Dispense End Setup* instruction and / or a Z Clearance instruction in a previous memory address.

Dispense End Setup and *Z Clearance* instructions are registered using the **SETUP** key.

1.7 End Program

Registers the current memory address as the end of the program. The end program instruction will cause the tip to return to the home position at the end of the program cycle.

1.8 Dispense ON / OFF

The Dispense ON / OFF instruction will allow the user to program an instruction which will turn the dispenser ON or OFF.

This is useful for turning the dispenser OFF before the end of a line to prevent excess material at the line end.

Problem: Too much material at the end of the line



Solution: Turn the dispenser OFF before the end of the line

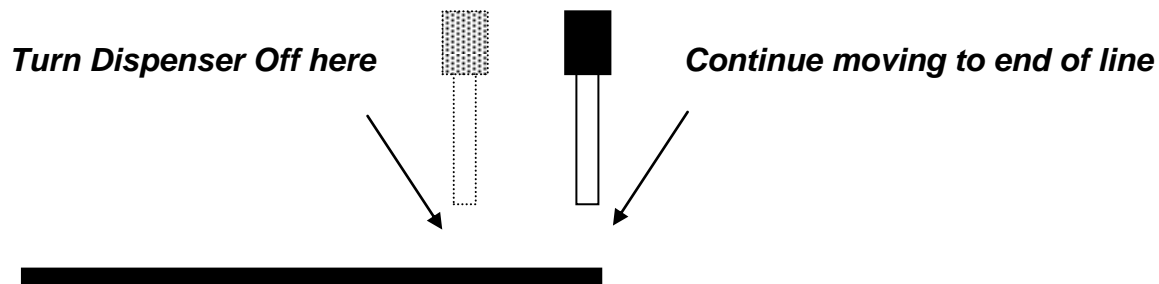

To register a DISPENSE OFF instruction, jog the tip to the XYZ location where you want the dispenser OFF, enter that location as a Line Passing point, then press the **ENTER** key and select **Dispense ON / OFF**.

Press **1** to select Dispenser ON, or press **2** to select Dispenser OFF.

1.9 GOTO Address

The GOTO Address function causes the program to jump to a specified memory address.

1.10 Step & Repeat X

Step & Repeat X allows a group of instructions to be run repeatedly, stepping a given distance in the X-axis or Y-axis between each cycle.

Step & Repeat X is useful when a fixture is mounted on the robot, which holds many identical work pieces aligned in rows and columns. The user needs only to create a program for the first work piece in the fixture, and then use the Step & Repeat function to dispense to the other work pieces.

The Step & Repeat function will allow the user to define the number of rows, the number of columns, the X Offset between each part, and the Y Offset between each part.

If, for example, we have a program (number 20) which dispenses four dots of material on a work piece:

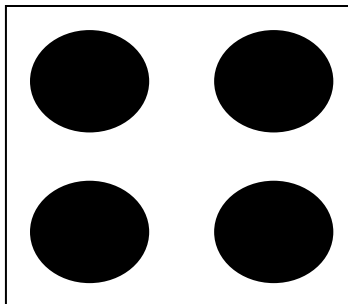

The program would consist of the following eight instructions:

Address	Instruction
1	Dispense End Setup: H.Speed = 100 mm/s, L.Speed = 15 mm/s, L.Length = 5mm
2	Z Clearance: Relative 10 mm
3	Point Dispense Setup: Disp.Time = 0.25 s Tail Time = 0.10 s
4	Dispense Point
5	Dispense Point
6	Dispense Point
7	Dispense Point
8	End Program

If a fixture is made which holds (12) work pieces, in four columns by three rows:

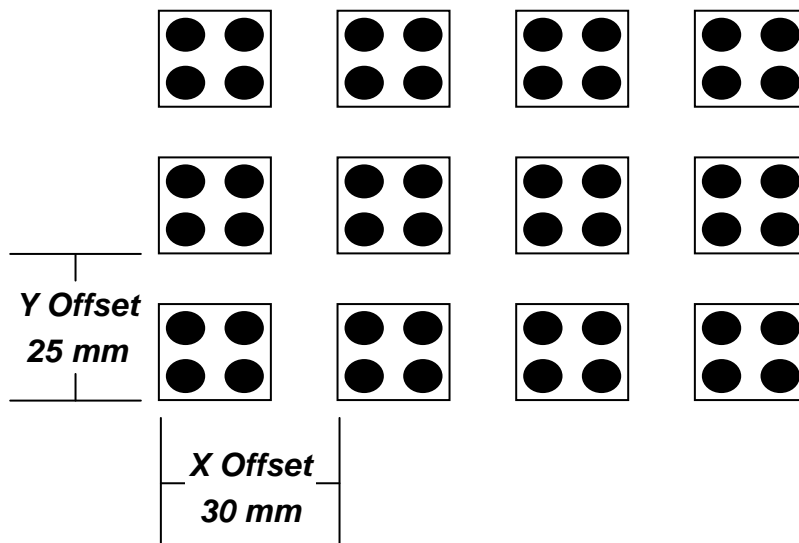

A Step & Repeat X instruction can be used to repeat the program at the additional (11) locations.

The instruction at memory address 8 should be changed from End Program to Step & Repeat X. To register a Step & Repeat X instruction at memory address 8, do the following:

	<i>Instruction</i>	<i>Display Shows</i>
1	Press the +1 or -1 keys until memory address 8 is shown in the display	ADDR: 8 PROG: 20 End Program
2	Press the Enter key, and then press the X→ key to change to page 2. Select Step & Repeat by pressing the key 3.	Step & Repeat Address, 8 ----- 1.X 2.Y, Start Address, Columns (X): Rows (Y):
3	Type 1 to select X direction, and then press ENTER .	Step & Repeat Address, 8 ----- 1.X 2.Y, 1 Start Address, Columns (X): Rows (Y): [F1] Address [F2]Label
4	The display will prompt you for the <i>Start Addr</i> : The start address is the memory address of the first instruction, which is part of this Step & Repeat group. In our example, we want to repeat all instructions starting with memory address number 4. Type 4 to specify memory address 4, and then press ENTER .	Step & Repeat Address, 8 ----- 1.X 2.Y, 1 Start Address, 4 Columns (X): Rows (Y):
5	Type 4 to specify four columns, and then press ENTER .	Step & Repeat Address, 8 ----- 1.X 2.Y, 1 Start Address, 4 Columns (X): 4 Rows (Y):

	<i>Instruction</i>	<i>Display Shows</i>
6	Type 3 to specify three rows, and then press ENTER .	Step & Repeat Address, 8 ----- X Offset: Y Offset: Unit: mm
7	In the above example, the X Offset between parts is 30 mm. Type 30 to specify an X Offset of 30 mm, and then press ENTER .	Step & Repeat Address, 8 ----- X Offset: 30 Y Offset: Unit: mm
8	In the above example, the Y Offset between parts is 25 mm. Type 25 to specify 25 mm, and then press ENTER .	Step & Repeat Address, 8 ----- 1. S Path 2. N Path Select:
9	The display will prompt you to select <i>1. S Path</i> or <i>2. N. Path</i> . Selecting <i>S Path</i> will cause the first row 1 to 4 to be dispensed, then the second row 4 to 1, and then the third row 1 to 4. Selecting <i>N PATH</i> will cause the first row 1 to 4 to be dispensed, then the second row 1 to 4, and then the third row 1 to 4. Press 1 to select S PATH , and then press ENTER .	Addr: 9 Prog:20 Empty
10	The program is now complete. Press ENTER , and then select End Program to mark address 9 as the new End Program instruction. Press the 7 key then press ENTER. Press RUN to run the program.	Addr: 10 Prog:20 Empty

The program will run in the following pattern and consists of the following instructions:

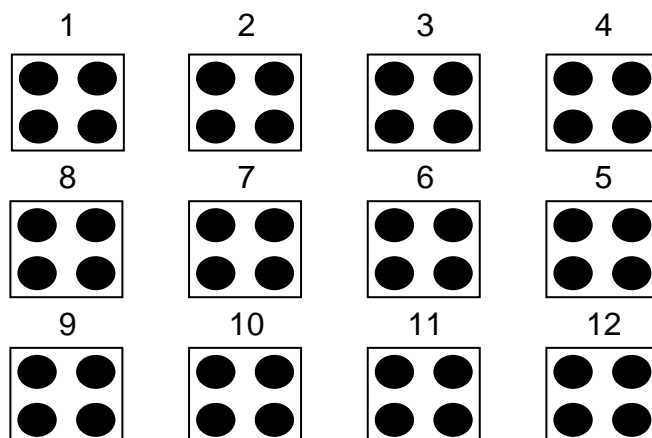

Address	Instruction
1	Dispense End Setup: H.Speed = 100 mm/s, L.Speed = 15 mm/s, L.Length = 5mm
2	Z Clearance: Relative 10 mm
3	Point Dispense Setup: Disp.Time = 0.25 s Tail Time = 0.10 s
4	Dispense Point
5	Dispense Point
6	Dispense Point
7	Dispense Point
8	Step & Repeat X: Cols: 4, Rows: 3, X Off: 30mm, Y Off: 25mm, Addr. 4, S Path
9	End Program

The previous example was done using S Path. The difference between S Path and N Path is the order in which the pieces are run:

Step & Repeat X:

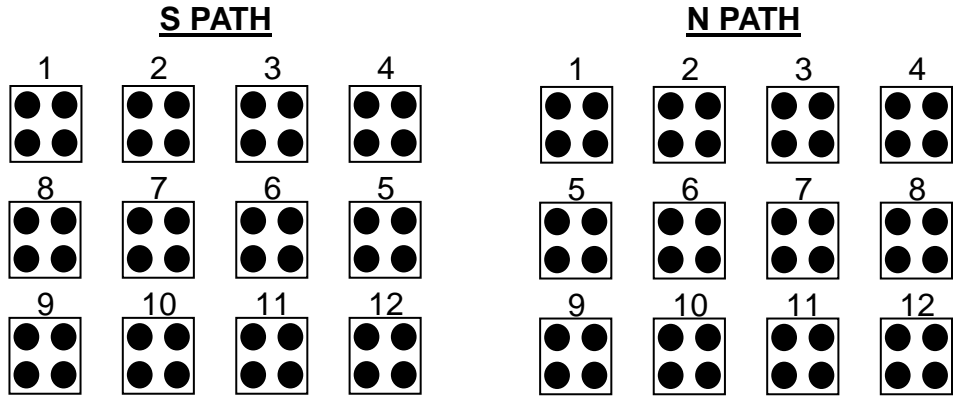

1.11 Step & Repeat Y

Step & Repeat Y works just as Step & Repeat X does, with one difference: priority is given to the Y-axis instead of the X-axis.

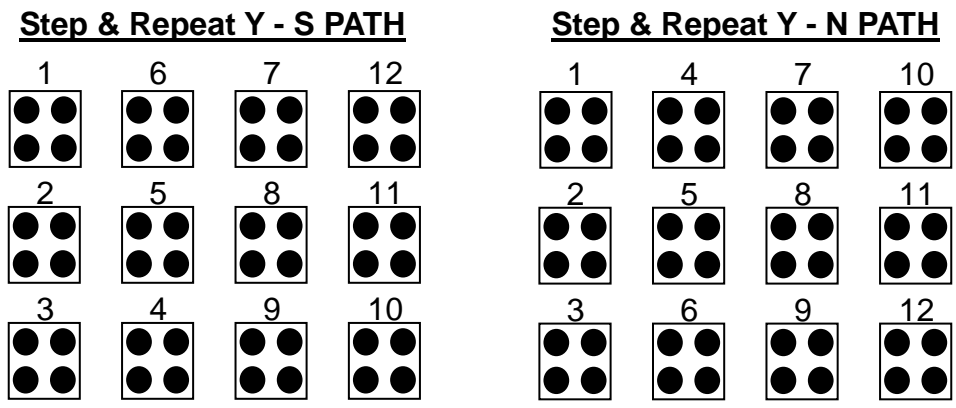

1.12 Brush Area

The Brush Area command causes the tip to 'paint' a defined area.

There are six Brush Area types: Rectangle, Circle, Rectangle 1, Rectangle Band, Circle Band and Circle1. The next pages provide a detailed description of all the Brush area types.

To register a *Brush Area* command, follow the instructions below.

	<i>Instruction</i>	<i>Display Shows</i>
1	Press ENTER to open the Point Menu	[POINT] 1/3 1 Dispense Dot 2 Line Start . . 7 End Program
2	Press X→ , to go to page 2	[POINT] 2/3 . . 4 Brush Area .
3	Press 4 to select Brush Area.	Brush Area Setup ----- 1.Rectangle 4.Rect Band 2.Circle 5.Circle Band 3.Rectangle 1 6. Circle 1 Select:
4	Press the numeric key corresponding to the brush area type then press ENTER	Brush Area Setup ----- 1.Rectangle 4.Rect Band 2.Circle 5.Circle Band 3.Rectangle 1 6.Circle 1 Width (mm) : Band (mm) :
5	Type the width value and press ENTER . Type the band value and press ENTER . Width and band values will be explained further in this section.	

1.12.1 Brush Area: Rectangle

Brush Area Rectangle causes the tip to 'paint' the defined area by passing back and forth along the X-axis, while moving the Y-axis a determined *Brush Width* distance after each pass along the X-axis.

After registering the Brush Area Rectangle command, teach a Line Start point at the top left corner of the area to be brushed and a Line End point at the bottom right corner of that area (the tip will not dispense a straight line between these two points):

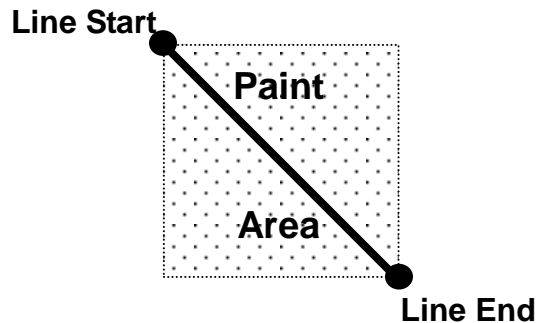

If, for example, a brush width of 5 mm was used, the tip will take the following path when the program is run:

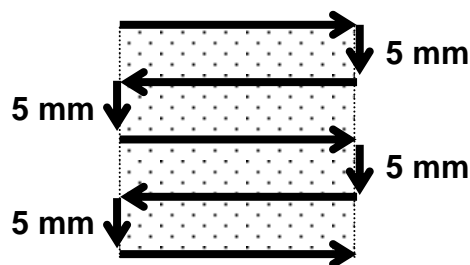

1.12.2 Brush Area: Circle

Brush Area Circle causes the tip to 'paint' the defined area by following a spiral path from the outside limit of the circle to the center of the circle. It works in reverse of the Circle 1 function.

After registering the Brush Area Circle command, jog the tip to a point on the outside limit of the circle to be brushed and register that location as a Line Start point. Then jog the tip directly across to the center of the circle and register that location as a Line End point (the tip will not dispense a straight line between these two points):

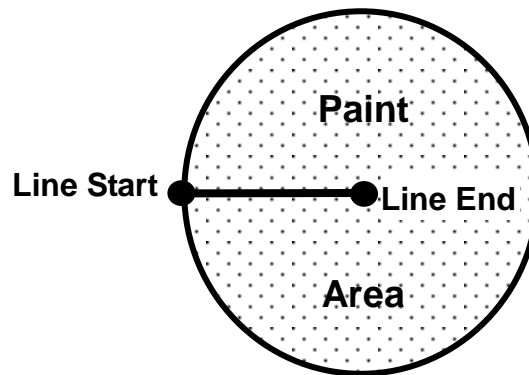

If, for example, a brush width of 5 mm was used, the tip will take the following path when the program is run:

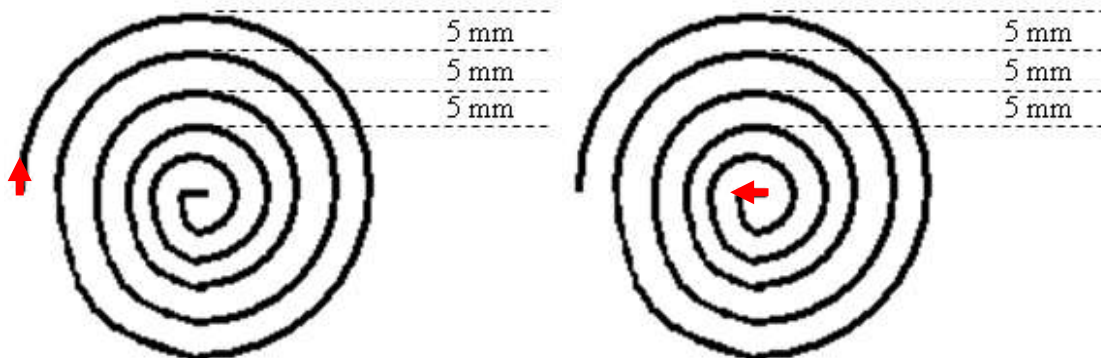

Closed Circle: from Outside of the Circle to the Center **Open Circle:** from Center of the Circle to out

An open or closed option is also available for this function. Selecting the Closed option will make a whole circle first before making the spiral. Selecting the Open option will make the spiral without closing the outer circle.

1.12.3 Brush Area: Rectangle 1

Brush Area Rectangle 1 causes the tip to 'paint' the defined area by following a square spiral path from the outside of the rectangle to the center.

After registering the Brush Area Rectangle 1 command, teach a Line Starting point at the top left corner of the area to be brushed and a Line End point at the bottom right corner of that area (the tip will not dispense a straight line between these two points):

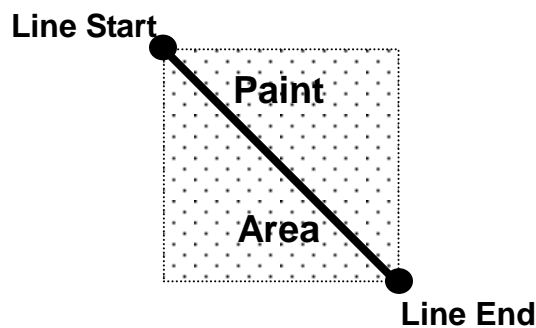

If, for example, a brush width of 5 mm was used, the tip will take the following path when the program is run:

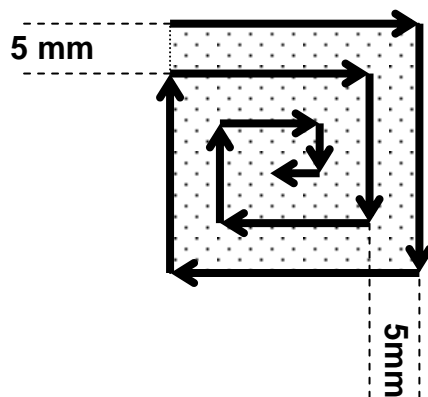

1.12.4 Brush Area: Rect. Band

Brush Area Rect. Band causes the tip to 'paint' a defined rectangular band area by following a square spiral path from the outside of the rectangle to the center.

After registering the Brush Area Rect. Band command, teach a Line Start point at the top left corner of the area to be brushed and a Line End point at the bottom right corner of that area (the tip will not dispense a straight line between these two points):

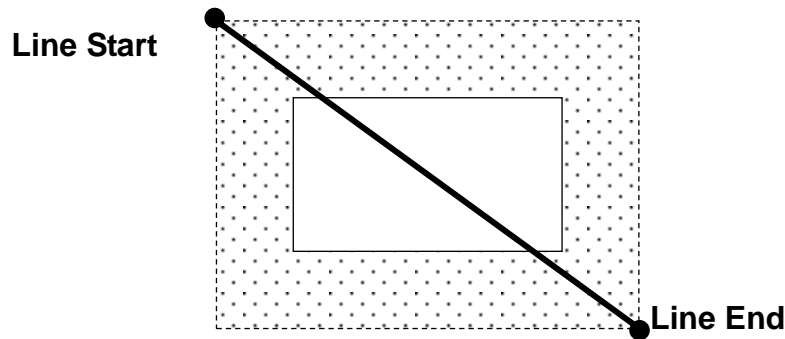

If, for example, a brush width of 5 mm and band of 10mm was used, the tip will take the following path when the program is run:

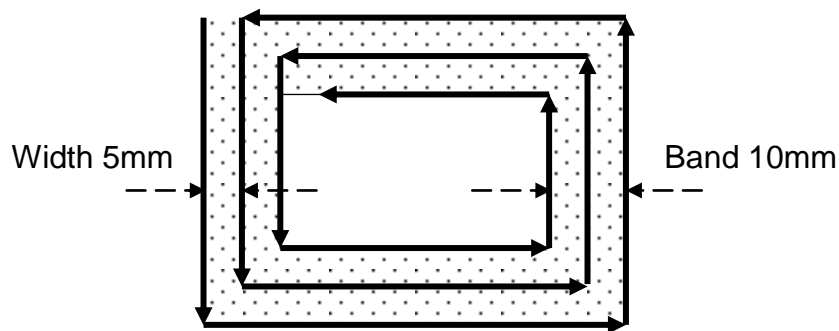

1.12.5 Brush Area: Circle Band

Brush Area Circle Band causes the tip to 'paint' a defined circular band area by following a spiral path from the outside limit of the circle to the center of the circle.

After registering the Brush Area Circle Band command, jog the tip to a point on the outside limit of the circle to be brushed and register that location as a Line Start point. Then jog the tip directly across to the center of the circle and register that location as a Line End point (the tip will not dispense a straight line between these two points):

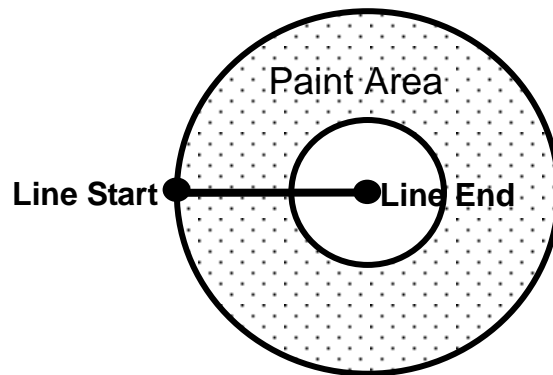

If, for example, a brush width of 5 mm and Band of 15mm was used, the tip will take the following path when the program is run:

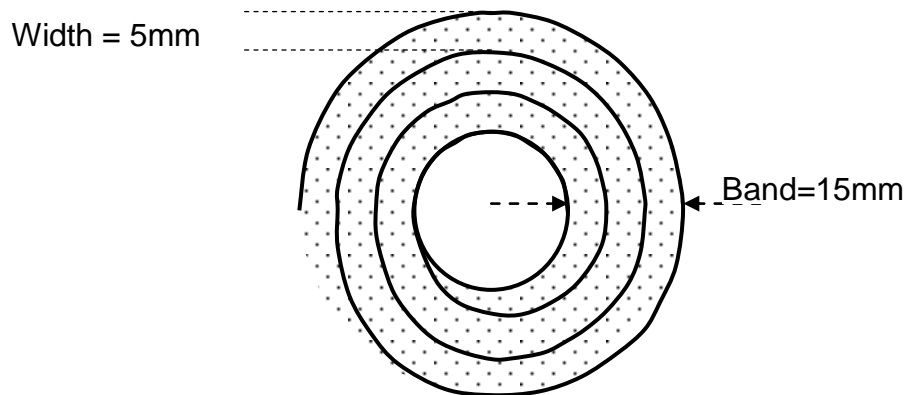

1.12.6 Brush Area: Circle 1

Brush Area: Circle 1, causes the tip to 'paint' the defined area by following a spiral path from the center of the circle to the outside limit of the circle. It works in reverse of the Circle function.

After registering the Brush Area Circle command, jog the tip to a point where you want to register the center of the circle and register that location as a Line Start. Then jog the tip directly across on the outside limit of the circle to be brushed and register that location as a Line End point (the tip will not dispense a straight line between these two points):

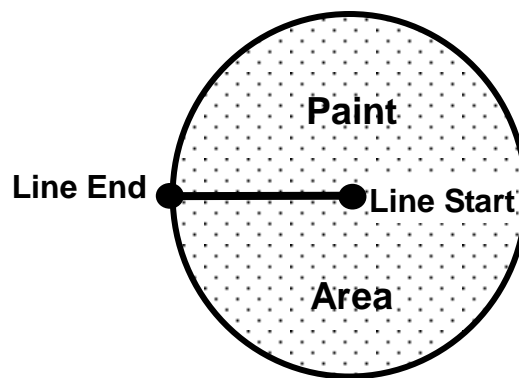

If, for example, a brush width of 5 mm was used, the tip will take the following path when the program is run:

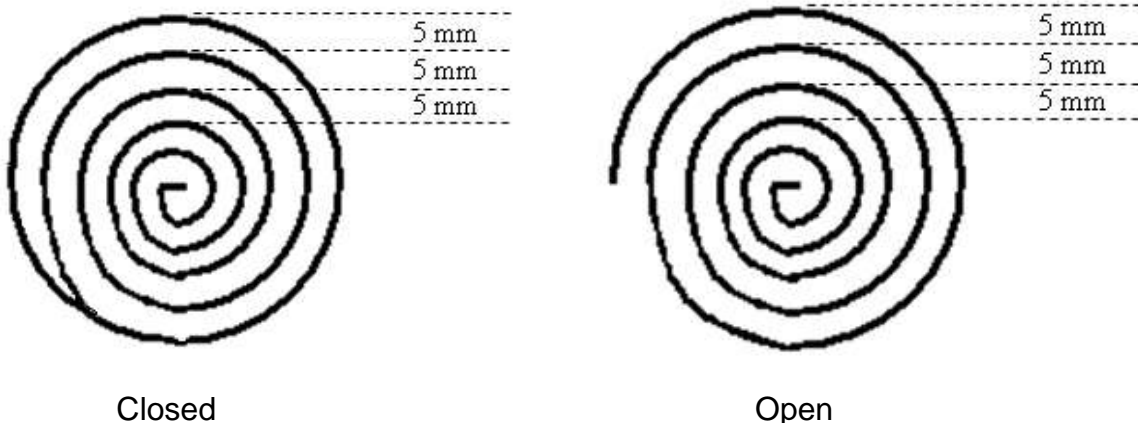

An open or closed option is also available for this function. Selecting the Closed option will make a whole circle first before making the spiral. Selecting the Open option will make the spiral without closing the outer circle.

1.13 Call Subroutine

A subroutine is a set of instructions that are located after the End Program instruction.

Call Subroutine causes the machine to jump to a specified memory address and execute the instructions found there using coordinates specified at the **Call Subroutine** instruction. When the *End Program* instruction for the subroutine is reached, program execution will continue at the address immediately after the **Call Subroutine** instruction.

The **Call Subroutine** function is most useful to repeat a pattern anywhere on the work-piece, as opposed to the *Step & Repeat* function where the pattern must be repeated in straight lines, at fixed distances from each other.

The following example illustrates the use of the *Call Subroutine* instruction. An explanation follows.

Address	Instruction
1	Line Speed = 20
2	Call Subroutine (X1,Y1,Z1) address 7
3	Call Subroutine (X2,Y2,Z2) address 7
4	Call Subroutine (X3,Y3,Z3) address 7
5	Call Subroutine (X4,Y4,Z4) address 7
6	End Program
7	Line Start (Xs,Ys,Zs)
8	Line End (Xe,Ye,Ze)
9	End Program

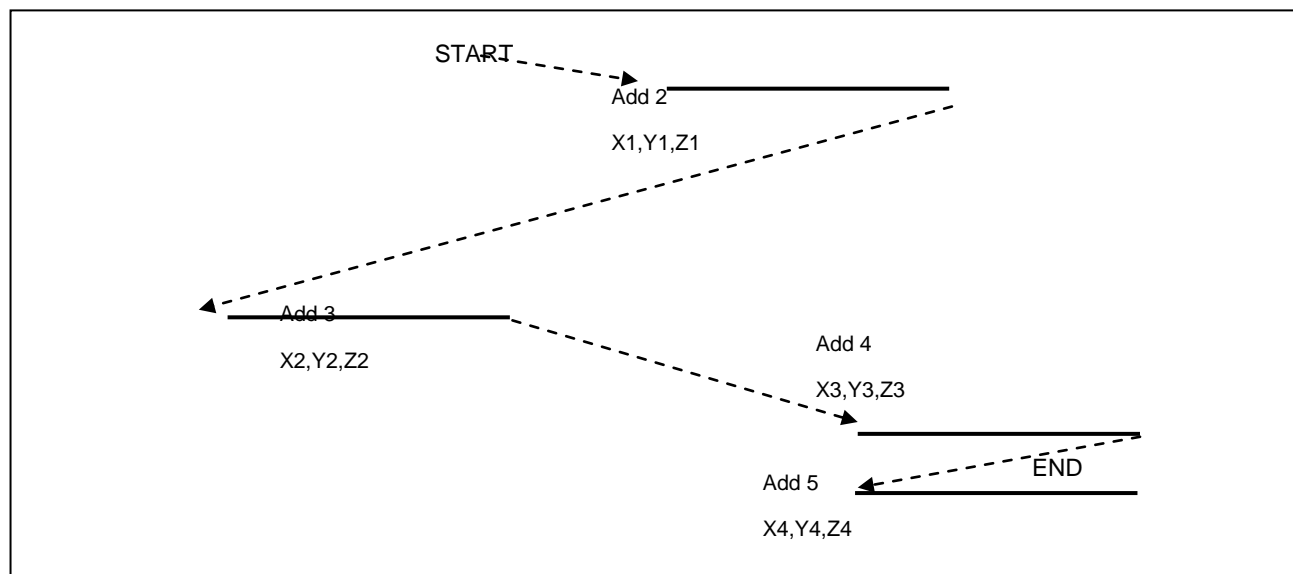

Addresses 7 and 8 comprise the subroutine that will be executed whenever it is called within the main program. The coordinates in the body of the subroutine (Xs,Ys,Zs,Xe,Ye,Ze) are not important; *the critical information is the relative position to each other*. The actual work will be performed on the coordinates in the main body of the program.

Before using the **Call Subroutine** instruction, the tip must be jogged to the first point where the user wants the work to occur. This point must correspond to the *relative* first point defined in the subroutine.

1.14 Call Program

Call Program will jump to the specified program number and execute the program data in the destination program until the End Program command is reached. When the destination program is executed, the robot will return to the calling program.

1.15 Set I/O

Set I/O registers an instruction, which either sets the value of an output signal or checks the status of an input signal.

When the Set I/O function is registered, the user is prompted to select *1. Input* or *2. Output*.

If **1. Input** is selected; the user can enter the input **Port** (input # 1 – 8), the input **Status** (1/0) and the address to **GOTO** if that input status occurs. The input status is (0) when the input pin is connected to ground. The input status is (1) if the input pin is disconnected.

If **2. Output** is selected, the user can enter the output **Port** (output # 0 – 8), and whether the output should be turned **ON** or **OFF**.

Please see **SECTION 6: Sample Programs** for an example of the *Set I/O* instruction.

1.16 Wait Point

Registers a Wait Point at the current X, Y, Z location. When executed, the tip will move to that location and wait for the specified period of time.

Wait Point can only be implemented on RUN Mode.

1.17 Stop Point

Registers a Stop Point at the current X, Y, and Z location. When executed, the tip will move to that location and wait until the start button is pressed.

1.18 Home Point

Registers an instruction to 'HOME' all axes, by sending them to the home position. It works like a "Move" command.

It works like an "End Program" function when registered at the end of the program. After program completion, the dispensing tip moves to the home position. If used in the body of the program, the tip is moved to the home position and the next instruction is executed.

This function uses the *Home Position Setup* coordinates (under F4 (Setup Menu)) if a new home position is made. Otherwise, it uses the default home position (X=0, Y=0, Z=0). See the Setup Menu for instructions on changing the location of the home position.

1.19 Loop Address

Registers an instruction, which will execute a group of instructions a user-specified number of times.

When the **Loop Address** instruction is registered, the display will prompt for an **Address** and **Count**.

Address is the memory address to jump to from the current address. This address must be less than the current memory address.

Count is the number of times to execute the loop.

1.20 Dummy Point

Registers the current XYZ location as a Dummy point. The tip will simply pass through this point. A dummy point is useful for avoiding obstacles on the work piece.

1.21 Initialize

Registers an Initialize point causing the robot to perform a mechanical initialization. The tip will home to position (0,0,0) and the robot will re-find the home position using the home position sensors.

1.22 Label

Registers a label that can be used as a reference when used with the GOTO, Loop address, Set I/O, Step & repeat X, Step & repeat Y and Call Subroutine commands.

Label can be used instead of Address number. A maximum of 64 labels is permitted per program; each label can have up to 8 characters.

1.23 Display Counter

The *Display Counter* instruction shows a counter at the bottom of the teach pendant screen while a program is running. Every time this instruction is executed, the counter increases by one and is shown again on the screen. The counter begins at one (1).

1.24 Loop Counter

The *Loop Counter* either clears or keeps the current tally of the counter when an I/O signal is received. The tally is cumulatively added to the current count on the display counter.

1.25 Dispense Output Setup

Dispense Output Setup assigns the dispense output port number (0-8) for the line and dot under control of the line dispense setup and point dispense setup. The default dispense output port number is zero.

Programming Sample:

Address	Instruction
1	Line Dispense Setup <i>Head Time: 0.1</i> <i>Tail Time: 0.1</i> <i>Node Time: 0</i> <i>Tail Length: 0</i>
2	Dispense Output: 3
3	Line Start
4	Line End
5	Line Dispense Setup <i>Head Time: 0.15</i> <i>Tail Time: 0.1</i> <i>Node Time: 0</i> <i>Tail Length: 0</i>
6	Dispense Output: 2
7	Line Start
8	Line End
9	Point Dispense Setup <i>Head time: 0.1</i> <i>Tail time: 0.1</i>
10	Dispense output: 1
11	Dispense Dot
12	Dispense Dot
	End Program

2. F2 (Menu 1)

2.1 Group Edit

Group Edit is a powerful utility, which allows several different functions to be applied to a user-defined group of addresses. These functions include copy, delete, move, multiply line speed, multiply dispense times, apply X Offset, apply Y Offset, and apply Z Offset.

2.1.1 Copy

For example, to use group edit to copy addresses 1 – 20 in the current program to memory address 21 - 40:

	<i>Instruction</i>	<i>Display Shows</i>
1	Press the F2 (MENU 1) key, then 1 to select <i>Group Edit</i> . The display will prompt the user to enter the starting memory address of the group to edit (From) and the ending number of the group to edit (To).	GROUP EDIT FROM: 1 TO: 1 (1 <-> 4000) F1: All F2: End
2	Type 1 then press ENTER to register 1 in <i>From</i> . Type 20 then press ENTER to register 20 in <i>To</i> .	GROUP EDIT ADDR: 1-20 ----- 1.Copy 5.Dispense Time 2.Delete 6.Offset 3.Move 7.Offset (R.E) 4.Line Speed Select:
3	The <i>Group Edit</i> menu will then appear, allowing the user to select an operation to be applied to the range of points. Press 1 to select <i>Copy</i> . Then press ENTER .	GROUP COPY ----- SOURCE 1-20 Destination:
4	The display will prompt the user to type the destination memory address where the data will be copied. Press the Clear key to erase the old value, then type 21 and press ENTER to select destination memory address number 21.	GROUP COPY SOURCE 1-20 Destination: 21 1.Yes 2.No Select:
5	The display will now prompt the user to confirm the copy. Press 1 and then press ENTER to select <i>Yes</i> and perform the copy.	

2.1.2 Delete

To use group edit to delete addresses 15 – 25 in the current program:

	<i>Instruction</i>	<i>Display Shows</i>
1	<p>Press the F2 (MENU 1) key, then 1 to select <i>Group Edit</i>.</p> <p>The display will prompt the user to enter the starting memory address of the group to edit (From) and the ending number of the group to edit (To).</p>	<pre>GROUP EDIT FROM: 1 TO: 1 (1 <-> 4000) F1: All F2: End</pre>
2	<p>Type 15 then press ENTER to register 15 in <i>From</i>.</p> <p>Type 25 then press ENTER to register 25 in <i>To</i>.</p>	<pre>GROUP EDIT ADDR: 15-25 ----- 1.Copy 5.Dispense Time 2.Delete 6.Offset 3.Move 7.Offset (R.E) 4.Line Speed Select:</pre>
3	<p>The <i>Group Edit</i> menu will then appear, allowing the user to select an operation to be applied to the range of points.</p> <p>Press 2 to select <i>Delete</i>. Then press ENTER</p>	<pre>GROUP DELETE ADDR: 15-25 ----- 1. Yes 2. No Select:</pre>
4	<p>The display will now prompt the user to confirm the deletion.</p> <p>Press 1 and then press ENTER to select Yes and delete the data.</p>	

2.1.3 Move

To use group edit to move addresses 10 – 20 in the current program to memory addresses 50 – 60:

	<i>Instruction</i>	<i>Display Shows</i>
1	<p>Press the F2 (MENU 1) key, then 1 to select <i>Group Edit</i>.</p> <p>The display will prompt the user to enter the starting memory address of the group to edit (From) and the ending number of the group to edit (To).</p>	<pre>GROUP EDIT FROM: 1 TO: 1 (1 <-> 4000) F1: All F2: End</pre>
2	<p>Type 10 then press ENTER to register 10 in <i>From</i>.</p> <p>Type 20 then press ENTER to register 20 in <i>To</i>.</p>	<pre>GROUP EDIT ADDR: 10-20 ----- 1.Copy 5.Dispense Time 2.Delete 6.Offset 3.Move 7.Offset (R.E) 4.Line Speed Select:</pre>
3	<p>The <i>Group Edit</i> menu will then appear, allowing the user to select an operation to be applied to the range of points.</p> <p>Press 3 to select <i>Move</i>. Then press ENTER</p>	<pre>GROUP MOVE ----- SOURCE 10-20 Destination:</pre>
4	<p>The display will prompt the user to type the destination memory address where the data will be moved.</p> <p>Press the Clear key to erase the old value, then type 50 and press ENTER to select destination memory address number 50.</p>	<pre>GROUP MOVE SOURCE 10-20 Destination: 50 1.Yes 2.No Select:</pre>
5	<p>The display will now prompt the user to confirm the move. Press 1 and then press ENTER to select Yes and move the data.</p>	

2.1.4 Line SP (Line Speed)

To use group edit to increase all of the line speed commands in memory address range 1 – 200 by 20 %:

	<i>Instruction</i>	<i>Display Shows</i>
1	<p>Press the F2 (MENU 1) key, then 1 to select <i>Group Edit</i>.</p> <p>The display will prompt the user to enter the starting memory address of the group to edit (From) and the ending number of the group to edit (To).</p>	<pre>GROUP EDIT FROM: 1 TO: 1 (1 <-> 4000) F1: All F2: End</pre>
2	<p>Type 1 then press ENTER to register 1 in <i>From</i>.</p> <p>Type 200 then press ENTER to register 200 in <i>To</i>.</p>	<pre>GROUP EDIT ADDR: 1-200 ----- 1.Copy 5.Dispense Time 2.Delete 6.Offset 3.Move 7.Offset (R.E) 4.Line Speed Select:</pre>
3	<p>The <i>Group Edit</i> menu will then appear, allowing the user to select an operation to be applied to the range of points.</p> <p>Press 4 to select <i>Line Speed</i>. Then press ENTER.</p>	<pre>GROUP LINE SPEED ADDR: 1-200 ----- Multiple Value:</pre>
4	<p>The display will prompt the user to type the Multiple Value to be applied to the line speeds.</p> <p>For example, a value of 1.2 will increase all speeds by 20%. A value of 0.8 will decrease all speeds by 20%.</p> <p>Type 1.2 and press ENTER to select a multiplier of 1.2.</p>	<pre>GROUP LINE SPEED ADDR: 1-200 ----- Multiple Value: 1.2 1.Yes 2.No Select:</pre>
5	<p>The display will now prompt the user to confirm the change. Press 1 to select Yes. Then press ENTER</p> <p>All of the line speed instructions in the select range of points will now be multiplied by 1.2.</p>	

2.1.5 Dispense Time

To use group edit to increase all of the dispensing times (Point Dispense Setup) in memory address range 1 – 200 by 15%:

	<i>Instruction</i>	<i>Display Shows</i>
1	<p>Press the F2 (MENU 1) key, then 1 to select <i>Group Edit</i>.</p> <p>The display will prompt the user to enter the starting memory address of the group to edit (From) and the ending number of the group to edit (To).</p>	<pre>GROUP EDIT FROM: 1 TO: 1 (1 <-> 4000) F1: All F2: End</pre>
2	<p>Type 1 then press ENTER to register 1 in <i>From</i>.</p> <p>Type 200 then press ENTER to register 200 in <i>To</i>.</p>	<pre>GROUP EDIT ADDR: 1-200 ----- 1.Copy 5.Dispense Time 2.Delete 6.Offset 3.Move 7.Offset (R.E) 4.Line Speed Select:</pre>
3	<p>The <i>Group Edit</i> menu will then appear, allowing the user to select an operation to be applied to the range of points.</p> <p>Press 5 to select <i>Dispense Time</i>. Then press ENTER.</p>	<pre>GROUP DISPENSE TIME ADDR: 1-200 ----- Multiple Value:</pre>
4	<p>The display will prompt the user to type the Multiple Value to be applied to the dispense times.</p> <p>For example, a value of 1.15 will increase all dispense times by 15%. A value of 0.85 will decrease all dispense times by 15%.</p> <p>Type 1.15 and press ENTER to select a multiplier of 1.15.</p>	<pre>GROUP DISPENSE TIME ADDR: 1-200 ----- Multiple Value: 1.15 1.Yes 2.No Select:</pre>
5	<p>The display will now prompt the user to confirm the change. Press 1 to select Yes. Then press ENTER.</p> <p>All of the Point Dispense Setup instructions in the select range of points will now be multiplied by 1.15.</p>	

2.1.6 Offset

The Offset function allows all XYZ locations in a program to be shifted in the X, Y, or Z-axis by a user-defined distance.

To use group edit to add 15 mm to all X-axis values in memory address range 1 – 200:

	<i>Instruction</i>	<i>Display Shows</i>
1	<p>Press the F2 (MENU 1) key, then 1 to select <i>Group Edit</i>.</p> <p>The display will prompt the user to enter the starting memory address of the group to edit (From) and the ending number of the group to edit (To).</p>	<pre>GROUP EDIT FROM: 1 TO: 1 (1 <-> 4000) F1: All F2: End</pre>
2	<p>Type 1 then press ENTER to register 1 in <i>From</i>.</p> <p>Type 200 then press ENTER to register 200 in <i>To</i>.</p>	<pre>GROUP EDIT ADDR:1-200 ----- 1.Copy 5.Dispense Time 2.Delete 6. Offset 3.Move 7.Offset (R.E) 4.Line Speed Select:</pre>
3	<p>The <i>Group Edit</i> menu will then appear, allowing the user to select an operation to be applied to the range of points.</p> <p>Press 6 to select <i>Offset</i>. Then press ENTER.</p>	<pre>GROUP OFFSET ADDR: 1-200 ----- X Offset:0 Y Offset:0 Z Offset:0 Unit: mm</pre>
4	<p>The display will prompt the user to type the X, Y, and Z offset amounts to be added to all points in address range 1 – 200.</p> <p>Type 15 and press ENTER to add 15 mm to the X-axis values. Press ENTER two more times to leave the Y and Z offsets at zero.</p>	<pre>GROUP OFFSET ADDR: 1-200 ----- X Offset: 15 Y Offset:0 Z Offset:0 1.Yes 2.No Select:</pre>
5	<p>The display will now prompt the user to confirm the change. Press 1 to select Yes. Then press ENTER.</p> <p>15 mm will be added to all of the X-axis values in the selected range.</p>	

2.1.7 Offset to

This function allows to be corrected automatically the offset problems which can appear when changing the tip, the barrel and/or the item to be dispensed on.

Move the tip using the original coordinates stored in program memory with the MOVE button. The next step is to jog the tip to the where it should be. The robot will realign all of the data points with the original program.

	<i>Instruction</i>	<i>Display Shows</i>
1	Press Move key. The tip will move to the saved position that was recorded in the current Address. If the new tip location is slightly different from the last tip location, you should see that the tip is not exactly at the reference point.	Line Start X:50 Y:10 Z:35 X: 50, Y: 10, Z: 35
2	Jog the tip to the correct location for the reference point.	Line Start X:50 Y:10 Z:35 X: 50.3, Y: 10.5, Z: 35
2	Press the F2 (MENU 1) key, then 1 to select <i>Group Edit</i> . The display will prompt the user to enter the starting memory address of the group to edit (From) and the ending number of the group to edit (To).	GROUP EDIT FROM:1 TO:1 (1 <-> 4000) F1:All F2:End
3	Type 1 then press ENTER to register 1 in <i>From</i> . Type 200 then press ENTER to register 200 in <i>To</i> . The <i>Group Edit</i> menu will then appear, allowing the user to select an operation to be applied to the range of points. Press 7 to select <i>Offset to</i> . Then press ENTER	GROUP EDIT 1-200 1.Copy 5.Dispen.Time 2.Delete 6.Offset 3.Move 7.Offset to 4.Line Speed Select:
4	The program origin will be adjusted for the new tip location.	X:0.3, Y:0.5, Z:0.0

2.2 Expand Step & Repeat

Expand Step & Repeat will expand a step and repeat instruction to the actual data it represents. This can be useful in situations where the user must edit selected elements in a Step & Repeat group, although an expanded Step & Repeat instruction will occupy more memory space than an unexpanded instruction.

For example, if the following program was created:

Before:

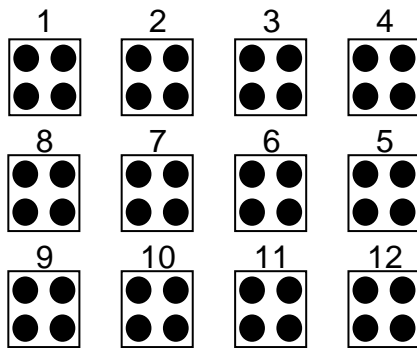

Address	Instruction
1	Dispense End Setup
2	Z Clearance
3	Point Dispense Setup
4	Dispense Point
5	Dispense Point
6	Dispense Point
7	Dispense Point
8	Step & Repeat X, Addr=4
9	End Program

The original program occupies 9 memory addresses.

If the user brings memory address number 8 into the display and then selects **F2 (MENU 1)**, *Expand Step & Repeat*, address 8 will be expanded into the 44 points which it represents, bringing the total number of memory addresses used to 51 (plus the End Program instruction at address 52).

After:

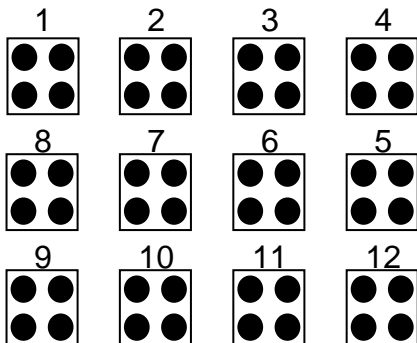

Address	Instruction
1	Dispense End Setup
2	Z Clearance
3	Point Dispense Setup
4	Dispense Point
5	Dispense Point
6	Dispense Point
7	Dispense Point
8	Dispense Point
9	Dispense Point
10	Dispense Point
.	.
.	.
.	.
51	Dispense Point
52	End Program

2.3 Program Name

Program Name allows the user to register a name for the current program. If a program name is registered, it will appear on the display when that program is selected in Run mode.

2.4 Z-axis Limit (mm)

Z-axis Limit allows the user to limit the range of the Z-axis.

Use the **Z↑** and **Z↓** keys to bring the Z-axis to the lowest point the Z-axis should be allowed to travel (the highest Z-axis numeric value), then select **F2 (Menu 1), 4. Z-axis Limit. (mm)**

The Z-axis range of motion will be limited to the current value.

2.5 Initial Output Port

Initial Output Port sets the ON/OFF status of the output signals at the start of each program cycle.

Initial Output Port value is the decimal representation of an 8 binary bit values controlling the 8 output signals.

For example,

Decimal Value	Output Status (X = on, blank = OFF)							
	#1	#2	#3	#4	#5	#6	#7	#8
0								
1	X							
2		X						
4			X					
8				X				
16					X			
32						X		
64							X	
128								X

2.6 *Debug Speed (mm/s)*

Debug Speed allows the debug speed to be set. This speed is the speed at which the tip will move when running in Debug mode. See also *Error! Reference source not found. Debug Program*

2.7 *Utility Menu*

Opens the Utility Menu. See *Error! Reference source not found.. Utility Menu.*

2.8 *Jog Speed*

The Jog Speed setting allows the user to select the jog speed for programming in Teach mode. The Jog speed can be set to Low, Middle or High speed.

The default value is **2. Middle.**

2.9 *Adjust Origin*

Allows the position of a program to be corrected using the reference points. Corrects: X offset, Y offset. Please refer to Section 2.9 “Adjust Position Setup.”

2.10 *Control by RS232*

This command allows the robot to be controlled via the RS232 port. This is possible with the Fisnar Windows software package *Robot Edit* feature.

To enable or disable this functionality, select *F2 (Menu 1) → Control by RS232* and select *Enable* or *Disable*.

2.11 Resume

Once a program has been interrupted, the **Resume** setting will determine if the program restarts from point # 1 or from the point at which it was interrupted, such as the middle of a program.

If **Resume** is set to **1** and a program is stopped by an emergency stop signal or by the enclosure door switch open signal, the program will restart from the point at which it was interrupted when the start button is pressed.

If **Resume** is set to **2** and a program is stopped by an emergency stop signal or by the enclosure door switch open signal, the program will restart from point #1.

The default value is **2**.

3. Utility Menu (within menu 1)

3.1 Program

Opens the program utility menu. The program utility menu includes four options:

1. Backup	Creates a backup of the current program in reserved backup location on the memory card. A separate backup location is reserved for each program number.
2. Restore	Restores program data backed up with 1. Backup above. The current program number data is restored.
3. Clear	Erases data in the current program number.
4. Copy	Copies the current program number to a different program number.

3.2 Memory

Opens the Memory utility menu. **THE MASTER PASSWORD is 777.**

1. Backup	Creates a backup of the entire memory contents - all program numbers. The backup is written to a reserved location on the memory card.
2. Restore	Restores the entire contents of the robot memory backed up with 1. Backup above.
3. Clear	Erases the entire contents of the robot memory. If Clear is selected, the user will be prompted for a password.

3.3 Teach Pendant

Opens the Teach Pendant utility menu. The Teach Pendant utility menu includes two options:

1. Backup	Copies the current program number data to the Teach Pendant.
2. Restore	Restores the contents of the Teach Pendant memory into the current program number.

The above teach pendant utilities provide an easy method of moving program data from one robot to another

3.4 Relocate Data

The Relocate Data function allows the position of a program to be corrected, including correction for X offset, Y offset and angle of rotation.

If, for example, the work piece fixture has been changed, the program position can be adjusted automatically for the new fixture.

The Relocate Data function requires two reference points for the calculations. Choose two point locations from your program, which will be used as reference points. For example, to relocate the program after a fixture change:

	<i>Instruction</i>	<i>Display Shows</i>
1	In this example, memory address 3 is the first reference point and memory address 4 is the second reference point. Jog the tip to the new, correct position for the first reference point.	
2	Press the MENU 2 key, then select Save Temp Point to save the location. The display will prompt for the temporary point number to save.	Save temp point ----- Point (1-9): Relocate Save To 1,2 Point

	<i>Instruction</i>	<i>Display Shows</i>
3	Press 1 to save the first location in temporary position #1. Then press ENTER	
4	Jog the tip to the new, correct position for the second reference point.	
5	Press the MENU 2 key, then select Save Temp Point to save the location. The display will prompt for the temporary point number to save.	Save temp point ----- Point (1-9): Relocate Save To 1,2 Point
6	Press 2 to save the second location in temporary position #2. Then press ENTER	
7	Press F2 (Menu 1) , then 7. Utility Menu , and select Relocate Data .	Relocate Data ----- 1.All Points 2.Some Points SELECT:
8	Press 1 to select <i>All Points</i> . Then press ENTER	Relocate All Point S1-> S2->
9	Type 3 and press ENTER to designate memory address number 3 as reference point 1 (temp point #1).	Relocate All Point S1->3 S2->
10	Type 4 and press ENTER to designate memory address number 4 as reference point 2 (temp point #2).	Relocate All Point S1->3 S2->4
11	The program location will be adjusted for X offset, Y offset and angle of rotation.	

3.5 *Lock or Unlock Program*

Lock or Unlock Program allows the user to protect a program from editing. If the program is locked, the user will not be able to change any of the program data. Unlocking the program will allow the data to be changed again.

3.6 *Password Setup*

Password Setup allows the password to be set or reset for the current program.

To set the password, select **F2 (MENU 1)**, *Utility Menu*, and *Password Setup*. The user will be prompted for a **NEW PASSWORD**. Type the new password and press **ENTER**.

If the password is left blank and **ENTER** is pressed, the password will be removed. After changing or resetting the password, the robot power should be turned off.

The purpose of the password is to protect the program from unauthorized editing. The user will not be allowed to enter TEACH mode unless the correct password is entered. If the password is forgotten, the master password (777) can be used to gain access to the program.

3.7 *Cycle Counter*

When in run mode, the first line of the display shows the number of program cycles, which have run to completion for the current program number: [RUN MODE][X]

It is possible to reset this number by selecting **F2 (MENU 1)**, *Utility Menu*, *Cycle Counter*. When prompted for the **New Data**: press **0** and **ENTER** to reset the cycle counter.

It is also possible to cause an alarm to be generated after a fixed number of program cycles. Select **F2 (MENU 1)**, *Utility Menu*, *Cycle Counter*. When prompted for the **New Data**: type the number of program cycles to complete before generating the alarm and press **ENTER**.

In run mode, when the set number of program cycles has been completed, the display will show **Counter Full [Shif+Enter]** and by pressing the shift+enter buttons the robot will be disabled and you can run the program again.

3.8 Key Beep

It allows you to turn on the key beep selecting the ENABLE option and it will turn off if the DISABLE option is selected.

3.9 Test Function

The F4000N Series robots offer the convenience of the Test Function command.

The Test Function is a diagnostic command used for troubleshooting your robot easily through the robot Teach Pendant.

Instructions

- 1) After initializing the robot, press the F2 button *MENU 1* on the Teach Pendant.
- 2) Select *Utility Menu* (see below).
- 3) Select *Test Function* (see below).

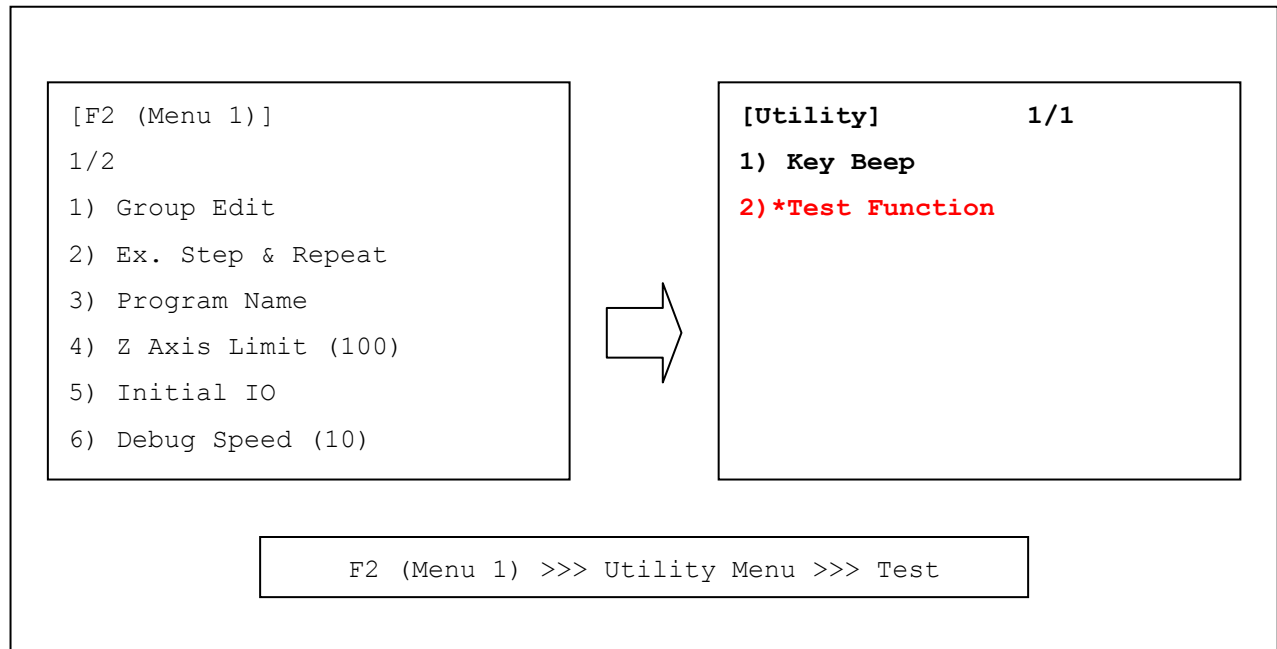

<p>Test Home Sensor Move Table by Hand</p> <p>-----</p> <p>X: 0 0 Y: 0 0 Z: 0 0</p>	<p>Teach Pad Test</p> <p>Press Key on Teachpad</p> <p>-----</p> <p>SCANCODE:</p>
<p>Test Front Panel</p> <p>Push the front panel button</p> <p>START BUTTON : 1 TEACH BUTTON : 1 EMERGENCY STOP : 0 PROGRAM NUMBER : 1</p>	<p>RS232 Test</p> <p>Cross RS232 Pin2 & Pin3</p> <p>-----</p> <p>Send Char:</p> <p>!!! NO RESPONSE !!!</p>
<p>IO Test</p> <p>-----</p> <p>IN: 1 1 1 1 1 1 1 1 1 1 OUT: 0 0 0 0 0 0 0 0 0 0</p> <p>Press Key 1~8 Set Output Press Key 9 Set Dispenser</p>	<p>Motor Test</p> <p>Table go & back (10mm)</p> <p>-----</p> <p>1. X 2. Y 3. Z</p>

4. F3 (Menu 2)

4.1 Numerical Move

Allows the tip to be positioned numerically by entering a number for the X, Y and Z values.

4.2 Save Temp Point

Save Temp Point saves the current XYZ position in a temporary memory area numbered (1 – 9). The save temp point function is also used with the Relocate Data function.

See **SECTION 5: 3.4 Relocate Data**.

4.3 Move To Temp Point

Move To Temp Point retrieves a XYZ position, which was stored with Save Temp Point.

4.4 Undo Program

Cancels the last change to the program. Returns to the program state prior to the last change.

4.5 Redo Program

Re-does the last change to the program, which was canceled with Undo.

4.6 Debug Program

Runs the program in Debug mode, using the speed set in Debug Speed starting at the current point location.

4.7 Move To Home Position

Move To Home Position will move the tip to the home location using either the default values (X=0, Y=0, Z=0) or the user-specified location defined in the *Setup → Home Position Setup* command.

This command cannot be used as a program instruction. It can be used during program editing to confirm the location of the home position.

4.8 System Information

System information will display the dispensing Software version currently installed in the robot.

4.9 Execute Point

Execute Point will run a selected command. Use the & keys to locate the command that you want to execute.

For example, if you select an address containing a circle, the Execute Point will cause the tip to move in a circular path.

4.10 Program List

Program List allows the operator to see all programs previously written in the memory.

5. F4 (Setup Menu)

Below is a list of functions, which are found under the **SETUP** key. These functions are all related to the setup of dispensing parameters.

5.1 Line Speed

Registers the line speed used for all lines from the current memory address forward until another Line Speed instruction is found.

5.2 Line Dispense Setup

When dispensing high viscosity materials, there is often a delay from the moment the dispenser is turned on until the material begins to flow. The following parameters are set under this function: Head Time, Tail Time, Node Time and Tail Length.

The **Head Time** setting is a delay time used at the start of line dispensing to prevent the tip from moving along the line path until the material is flowing. The tip will move to the start of the line, turn on the dispenser and wait for the time period specified in the *head time* setting before moving. The time value can be adjusted to ensure that the material begins flowing at the same time as the line movement begins.

At the end of dispensing, a delay is often required after the dispenser is turned off, to allow the barrel pressure to equalize, before moving to the next point location. This prevents material from being 'spilled' where it is not wanted. This time delay at the end of dispensing is called the **Tail Time**.

The **Node Time** parameter enters a wait time that only affects the **Line Passing** command. Tip will pass through line passing point and will **wait at line passing point** with the dispenser **activated** for the time specified in the **Node Time**.

Usually the material continues flowing after the dispenser is off, due to pressure built in the system. **Tail Length** automatically turns off the dispenser at a user defined distance before the end of a line, preventing excess of material to be deposited at the end of the line.

The value will be used for all lines from the current memory address forward until another **Tail Length** instruction is found.

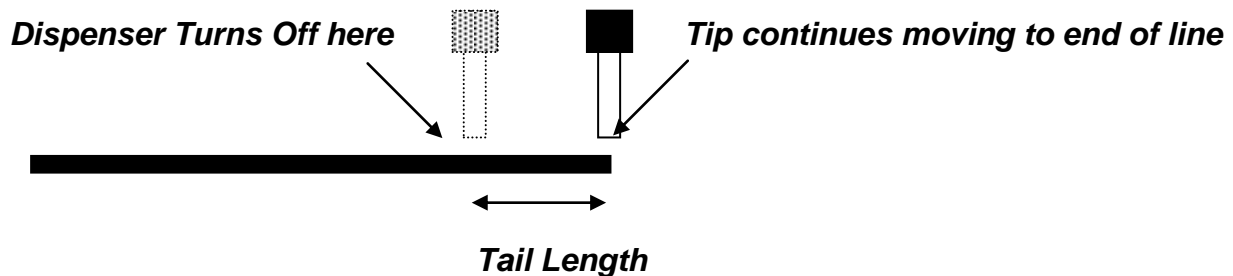

Values for the *Head Time* and *Tail Time* used when performing line dispensing are registered by pressing the **SETUP** key, then selecting **Line Dispense Setup**. The set values will be used by all lines from that memory address forward until new set of *Line Dispense Setup* values are found.

Please see **SECTION 6:Sample Programs** for an example of the *Line Dispense Setup* instruction.

5.3 Point Dispense Setup

Registers POINT DISPENSE SETUP values which set dispensing time and waiting time at the end of dispensing ('tail' time) for dots. The registered values will be used from the current memory address forward until another POINT DISPENSE SETUP instruction is found.

5.4 Dispense End Setup

Dispense End Setup allows the **L.Length**, **L. Speed** and **H. Speed** values to be registered at a memory address. These values will effect how far and how fast the tip rises after dispensing.

After dispensing a dot or line, it is often required to raise the tip a short distance at a slow speed. This allows the material to cleanly break free from the tip, without 'dragging' material where it is not wanted.

The distance and speed that the tip raises after dispensing is controlled by the **L.Length** and **L.Speed** settings.

After the tip raises the length specified by **L.Length** at the speed specified by **L.Speed**, the tip will continue rising to the **Z Clearance** height at the speed specified by **H.Speed**.

The purpose of specifying a Z Clearance height is to allow the tip to raise high enough to clear any obstacles it may encounter on the way to the next point.

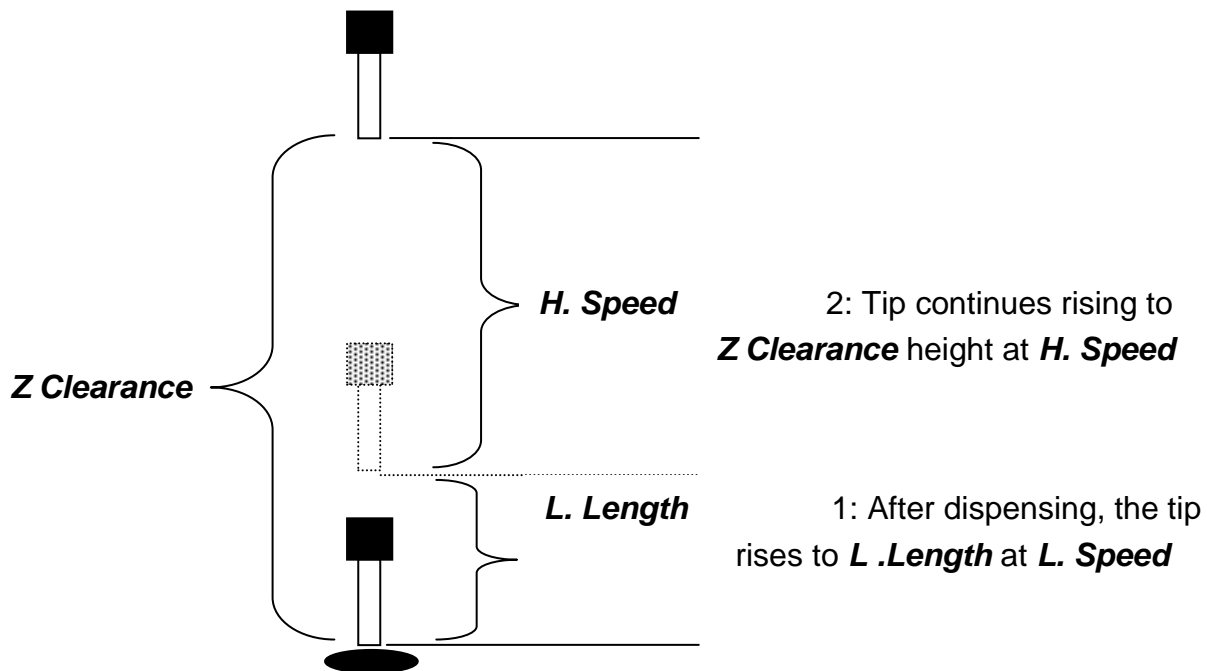

Values for **H.Speed**, **L.Speed** and **L.Length** are registered with the **Dispense End Setup** function by pressing the **SETUP** key, then choosing **Dispense End Setup**.

Once **Dispense End Setup** values have been registered at a memory address, all points after that memory address will use the values specified. If **Dispense End Setup** values are registered again, at a higher memory address, all points from that memory address forward will use the new values.

Please see **SECTION 6:Sample Programs** for an example of the **Dispense End Setup** instruction.

5.5 Z Clearance

The purpose of the Z Clearance function is to cause the tip to raise high enough to clear all obstacles as it moves from one point to another. If there are no obstacles between any of the program points, a small Z Clearance value, such as 5 mm, can be used to minimize the program cycle time.

Values for the Z Clearance are registered by pressing the **SETUP** key, then choosing **Z Clearance**. The Z Clearance value will be used by all points from that memory address forward until another Z Clearance value is found. Normally, a Z clearance instruction should be registered in the beginning of a program, at one of the first memory addresses.

The Z Clearance value may be specified as a relative value or an absolute value. When specified as a relative value, it is the distance to rise relative to the taught point location. When it is specified as an absolute value, it is a distance from the Z-axis zero position, where the tip will rise to, regardless of the Z-axis value of the taught point location. For example:

Z Clearance = 10 mm RELATIVE:

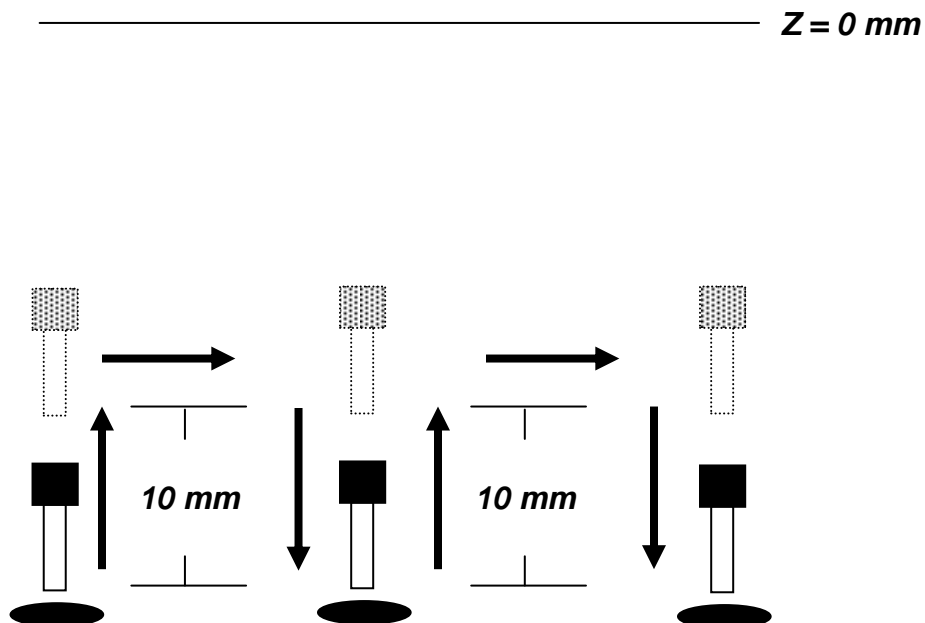

Z Clearance = 10 mm ABSOLUTE:

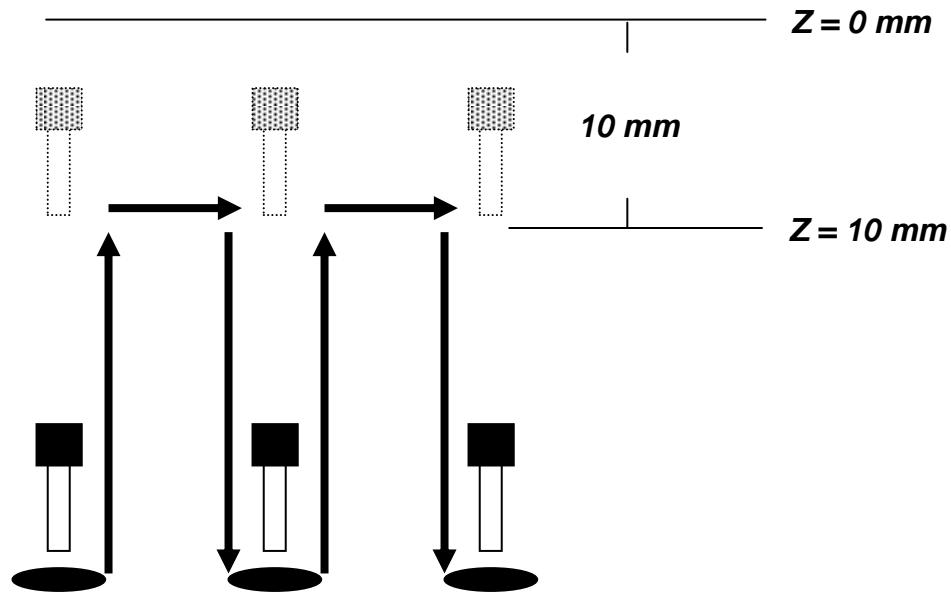

Please see **SECTION 6: Sample Programs** for an example of the *Z Clearance* instruction.

5.6 X/Y Move Speed

X/Y Move Speed sets default X and Y-axis movement speed as the tip moves between figures in a program, such as from one dispense point to another or from the end of line dispensing to the next start of line dispensing.

5.7 Z Move Speed

Z Move Speed sets default Z-axis movement speed as the tip moves between figures in a program, such as from one dispense point to another or from the end of line dispensing to the next start of line dispensing.

5.8 Home Position Setup

Home Position Setup allows the user to change the location of the program home position. The home position is the location where the tip will move to at the end of a program cycle if the “End Program” or “Home Point” instruction is registered. The default home position is (X=0, Y=0, Z=0).

To change the home position, jog the tip to the desired location for the new home position, then press **Setup** → **Home Position Setup**.

NOTE: When executing a program in TEACH MODE, the robot will move to the mechanical home position (X=0, Y=0, Z=0) at the start of every program cycle. When executing a program in RUN MODE, the robot will move to the home position set under *Setup* → *Home Position Setup*.

5.9 Adjust Position Setup

When the dispensing barrel or tip is removed and replaced, the new tip is often in a slightly different XYZ position than the old tip was. The F4200N robot has a software utility to adjust a program's origin, thereby correcting the tip's offset problem.

A reference point should be chosen someplace on the work piece fixture or on the work piece itself. The reference point must be registered in the program data. This only needs to be done one time, such as when the program is originally created.

	<i>Instruction</i>	<i>Display Shows</i>
1	Jog the tip to the reference point (i.e. X=10, Y=20, Z=30) Or if the reference point is an existing point in your program, press the MOVE key to bring the tip to that XYZ location.	
2	Press the SETUP key, and go to page two	[SETUP] 2/3 1 Home Position Setup 2 Adjust Position Setup : : 7 Acceleration
	Press 2 to Select Adjust Position Setup . The current point will be saved automatically. (The point will not be registered at any address in the program, but it will be saved as a global variable for the current program)	Set Adjust Position ----- X: 10 Y: 20 Z: 30

When the tip/barrel is changed, use the following procedure to adjust the program's origin for the new tip location:

	<i>Instruction</i>	<i>Display Shows</i>
	Switch the robot to RUN mode (the main unit mode switch is in the RUN position)	Counter:0 +-----+ START/HOME +-----+
1	Press the F1 key.	[Run Menu] 1/1 1. Reset Counter 2. Adjust Origin 3. Relocate Data
2	Press 2 to select <i>Adjust Origin</i> .	[MESSAGE BOX] ----- Press [ENTER] Adjust Position -----
3	Press the Enter key. The tip will move to the reference point previously saved (X=10, Y=20, Z=30). If the new tip's location is slightly different than the last tip's location, you should see that the tip is not exactly at the reference point	[MESSAGE BOX] ----- Move TIP ----- X10 Y20 Z30
4	Jog the tip to the correct location for the reference point. When the location is correct, press ENTER . All the coordinates in the current program will be offset to compensate the tip offset	[MACHINE HOME] +-----+ START/HOME +-----+

5.10 Retract Setup

The *Retract* function gives the programmer a high level of tip control at the end of line dispensing. This is useful when dispensing high viscosity or 'stringy' materials as it will lay the material's tail down on the dispensed bead.

There are five types of the *Retract Setup* functions: 0 (Normal), 1 (Back), 2 (Square Back), 3 (Forward) and 4 (Square Forward).

#0: RETRACT (NORMAL)

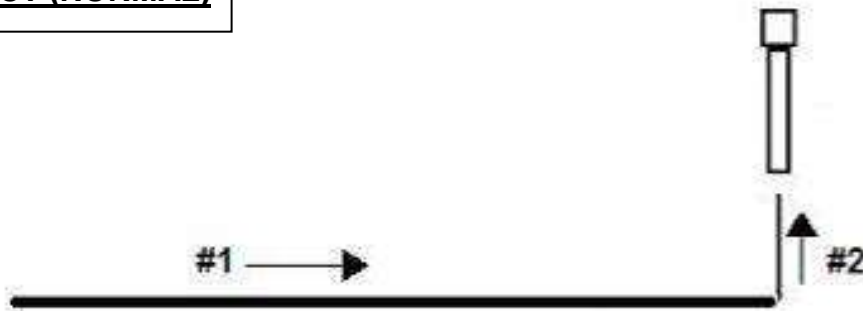

#1: RETRACT (BACK)

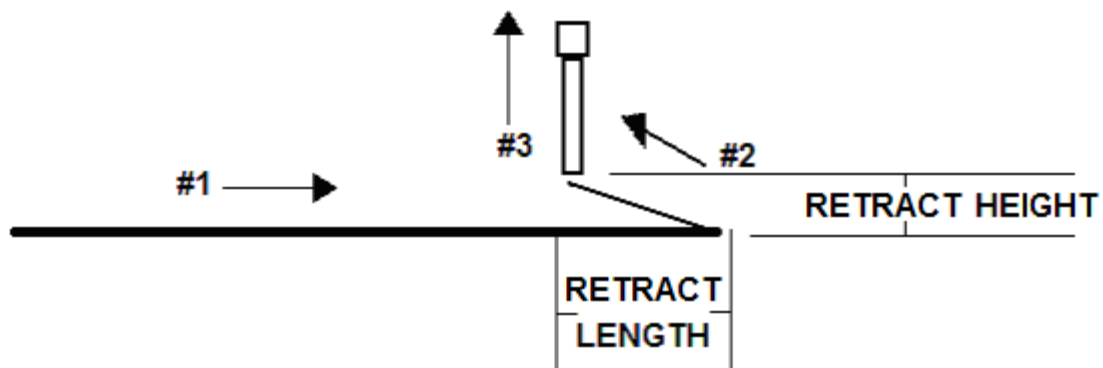

#2: RETRACT (SQUARE BACK)

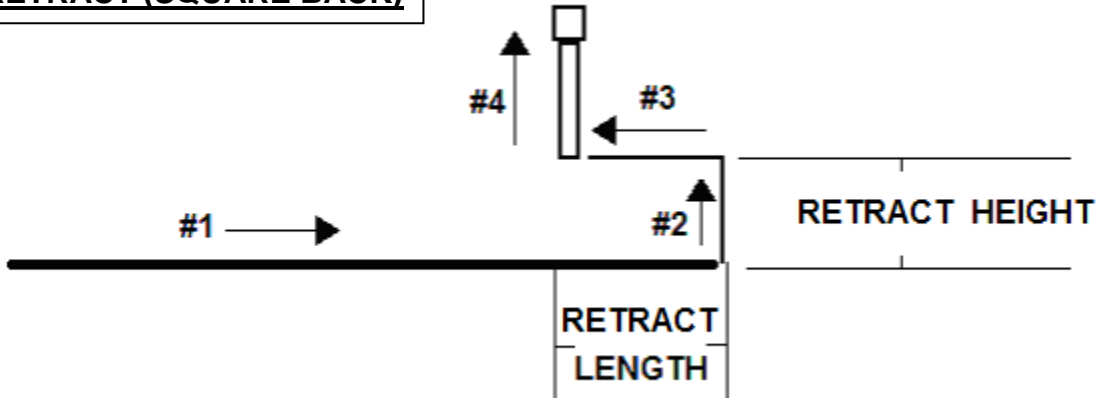

#3: RETRACT (FORWARD)

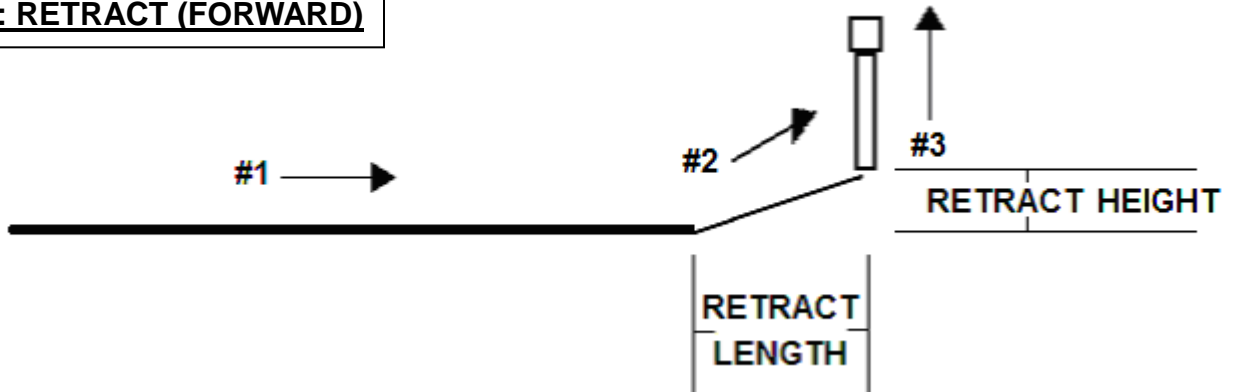

#4: RETRACT (SQUARE FORWARD)

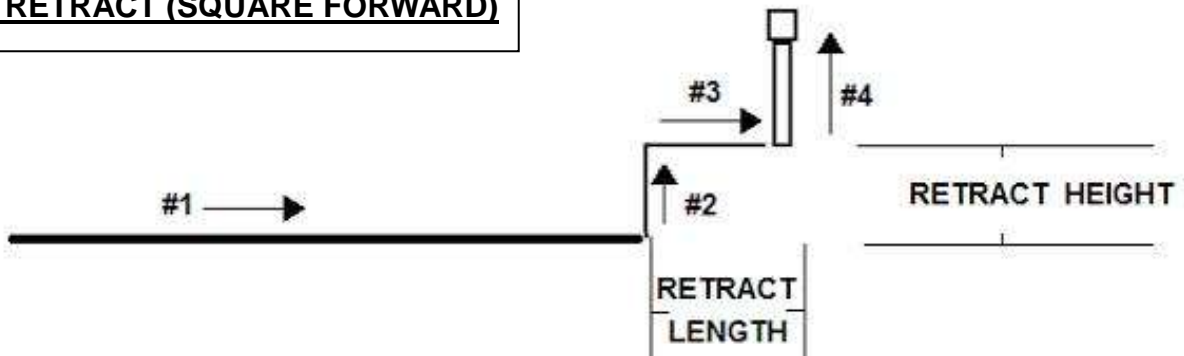

The retract function requires the following parameters:

RETRACT LENGTH: the distance to travel away from the line end point

RETRACT HEIGHT: the distance to rise as the tip moves away from the line end (must be smaller than the value of Z clearance in that point).

RETRACT SPEED: the speed at which the tip moves along the retract path

RETRACT TYPE:

0. NORMAL
1. BACK
2. SQUARE BACK
3. FORWARD
4. SQUARE FORWARD

Retract values will be used for all lines from the current memory address forward until another Retract instruction is found or the function is canceled.

5.11 Quickstep

This function causes the robot to move very fast from one point to another reducing the time of the dispensing cycle.

5.12 Auto Purge Setup

After the end of a program, the tip will go to the home position and material will be purged in a continuous loop according to the parameters registered in the Auto Purge Setup command.

This command is very useful for two part materials that have a very short pot life.

For example, if a Wait Time of 5s and a Purge Time of 2s is registered in the Auto Purge Setup, the following chart shows the Purge pattern.

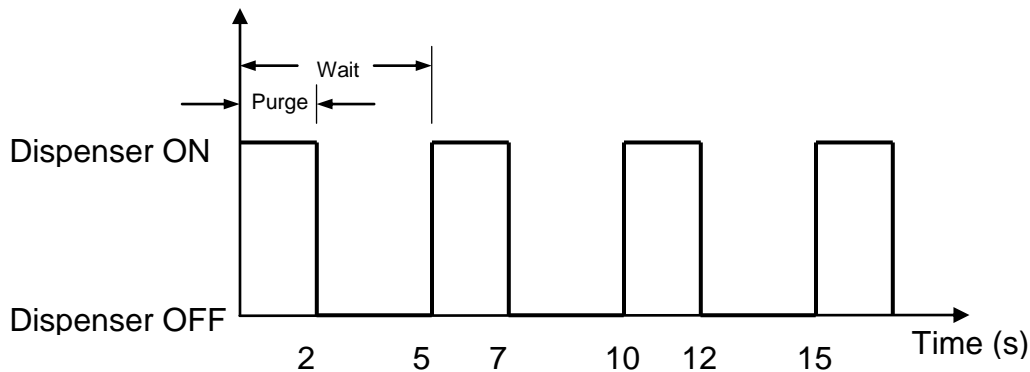

5.13 ESTOP Output Status

After receiving the emergency stop signal, the robot can set the status of all the outputs as:

- INITIAL: The status (On/Off) of the outputs is set as the status set by the **Initial IO** command.
- KEEP OUTPUT STATUS: The status (On/Off) of the outputs is left as it was before the emergency signal.

5.14 Acceleration

Controls the acceleration of each axis. The value entered in this setting is a robot parameter and its exact relation to the robot's acceleration is beyond the scope of this manual.

In general, the value of the acceleration parameter is inversely related to the robot's acceleration. A small value will result in a high acceleration and vice versa. Very small values can make the motors slip and can cause the driver cards to over heat.

The default value is 25 for all the axes and values lower than 15 are not recommended.

5.15 Pause Status

Pause Status sets the position to which the tip will move after pressing the Start button.

There are two options:

- Home position: The tip will move to the home position.
- Stand: The tip will stay at the position where the Start button was pressed.

SECTION 6: Sample Programs

1. Dots, Lines and Arcs – Sample Program

At typical program, containing dots, lines, and arcs, would appear as follows:

Addr.	Command	Notes
0001	Line Speed (50 mm/s)	Sets the line speed to 50 mm/sec
0002	Line Dispense Setup - Head Time: 0.30 sec - Tail Time: 0.25 sec - Node Time: 0.10 sec - Tail Length: 5 mm	Sets a wait time of 0.30 seconds at the start of all lines to give the material time to flow before moving along the line. Sets a wait time of 0.25 seconds at the end of all lines to give the material time to stop flowing before raising the tip. Sets a wait time of 0.10 sec at line passing point with the dispenser on. Sets a length of 5mm before the end of the line where the dispenser will be off.
0003	Point Dispense Setup - Dispense Time: 0.50 sec - Tail Time: 0.25 sec	Sets the dispensing time for all dots to 0.5 seconds. Sets the waiting time, after dispensing a dot, to 0.25 seconds.
0004	Dispense End Setup - H. Speed: 75 mm/sec - L. Speed: 15 mm/sec - L. Length: 10 mm	Programs the robot to rise, after dispensing dots and at the end of line dispensing. The tip will rise 10 mm (L. Length) at 15 mm/sec (L. Speed) then continues rising at 75 mm/sec (H. Speed) to the Z Clearance height.
0005	Z Clearance - 20 mm - Relative	Sets the Z Clearance value to 20 mm relative to the point location. The maximum height the tip will rise after dispensing is 20 mm above the Dot or Line End point

Addr.	Command	Notes
0006	Line Start (10, 10, 35)	Registers a Line Start point at X: 10 mm, Y: 10 mm, Z: 35 mm
0007	Line Passing (10, 20, 35)	Registers a Line Passing point at X: 10 mm, Y: 20 mm, Z: 35 mm
0008	Arc (5, 25, 35)	Registers an Arc point at X: 5 mm, Y: 25 mm, Z: 35 mm
0009	Line Passing (10, 30, 35)	Registers a Line Passing point at X: 10 mm, Y: 30 mm, Z: 35 mm
0010	Line End (10, 40, 35)	Registers a Line End point at X: 10 mm, Y: 40 mm, Z: 35 mm
0011	Dispense Dot (20, 20, 35)	Dispenses a dot at X: 20 mm, Y: 20 mm, Z: 35 mm
0012	Dispense Dot (20, 25, 35)	Dispenses a dot at X: 20 mm, Y: 25 mm, Z: 35 mm
0013	Dispense Dot (20, 30, 35)	Dispenses a dot at X: 20 mm, Y: 30 mm, Z: 35 mm
0014	End Program	Ends the program. Returns the tip to the home position.

2. Brush Area – Sample Program

Addr.	Command	Notes
0001	Line Speed (25 mm/s)	Sets the line speed to 25 mm/sec
0002	Line Dispense Setup - Head Time: 0.30 sec - Tail Time: 0.25 sec - Node Time: 0.10 sec - Tail Length: 5 mm	Sets a wait time of 0.30 seconds at the start of all lines to give the material time to flow before moving along the line. Sets a wait time of 0.25 seconds at the end of all lines to give the material time to stop flowing before raising the tip. Sets a wait time of 0.10 sec at line passing point with the dispenser on. Sets a length of 5mm before the end of the line where the dispenser will be off.
0003	Dispense End Setup - H. Speed: 75 mm/sec - L. Speed: 15 mm/sec - L. Length: 10 mm	Programs the robot to rise, after dispensing. The tip will rise 10 mm (L. Length) at 15 mm/sec (L. Speed) then continues rising at 75 mm/sec (H.Speed) to the Z Clearance height.
0004	Z Clearance - 20 mm - Relative	Sets the Z Clearance value to 20 mm relative to the point location. The maximum height the tip will rise after dispensing is 20 mm above the Line End point
0005	Brush Area - Rectangle - Brush Width: 5 mm	Sets a Rectangle area to be brushed with a brush width of 5 mm.
0006	Line Start (50, 10, 35)	Registers a Line Start point at X: 50 mm, Y: 10 mm, Z: 35 mm. This is the top left corner of the area to be brushed.
0007	Line End (90, 60, 35)	Registers a Line End point at X: 90 mm, Y: 60 mm, Z: 35 mm. This is the lower right corner of the area to be brushed.
0008	End Program	Ends the program. Returns the tip to the home position.

3. Step & Repeat – Sample Program

The program below will dispense four dots on each work piece.

There are three rows and four columns of parts loaded on the robot for a total of 12 parts.

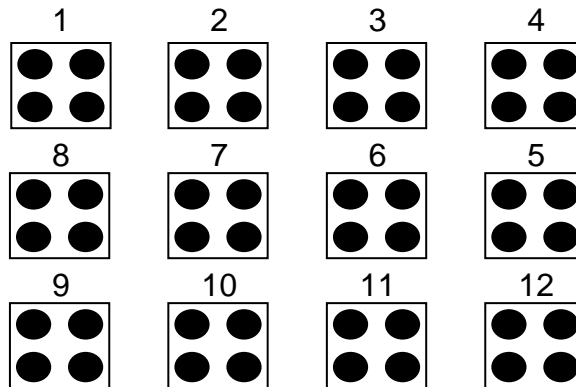

The parts are 25 mm apart in the X-axis.

The parts are 30 mm apart in the Y-axis.

Addr.	Command	Notes
0001	Point Dispense Setup - Dispense Time: 0.50 sec - Tail Time: 0.25 sec	Sets the dispensing time for all dots to 0.5 seconds. Sets the waiting time, after dispensing a dot, to 0.25 seconds.
0002	Dispense End Setup - H. Speed: 75 mm/sec - L. Speed: 15 mm/sec - L. Length: 10 mm	Programs the robot to rise, after dispensing. The tip will rise 10 mm (L. Length) at 15 mm/sec (L. Speed) then continues rising at 75 mm/sec (H. Speed) to the Z Clearance height.
0003	Z Clearance - 20 mm - Relative	Sets the Z Clearance value to 20 mm relative to the point location. The maximum height the tip will rise after dispensing is 20 mm above the Dot.

Addr.	Command	Notes
0004	Dispense Dot (180, 20, 35)	Dispenses a dot at X: 180 mm, Y: 20 mm, Z: 35 mm (First Part, first dot)
0005	Dispense Dot (180, 25, 35)	Dispenses a dot at X: 180 mm, Y: 25 mm, Z: 35 mm (First Part, second dot)
0006	Dispense Dot (185, 20, 35)	Dispenses a dot at X: 185 mm, Y: 20 mm, Z: 35 mm (First Part, third dot)
0007	Dispense Dot (185, 25, 35)	Dispenses a dot at X: 185 mm, Y: 25 mm, Z: 35 mm (First Part, four dot)
0008	Step & Repeat Y - Columns: 4 - Rows: 3 - X Offset: 25 mm - Y Offset: 30 mm - Start Address: 4 - 'S' Path	Registers the Step & Repeat instruction. The robot will repeat addresses 0004 – 0007 to complete a matrix of 4x3 (12) parts. The distance between parts is 25 mm in the X-axis and 30 mm in the Y-axis. The robot will follow an 'S' path, through the parts.
0009	End Program	Ends the program. Returns the tip to the home position.

4. Input / Output Signal Processing – Sample Program

The program below assumes a fixture holding 12 parts. The robot will move to the first part, then close output signal # 1 for 0.25 seconds.

The robot will then check the status of input signal #1 at the first part.

If the signal is closed, the robot will dispense a dot then move to the next part.

If the signal does not close within (2) seconds, the robot will skip this part and move to the next part. This process will be repeated for all (12) parts.

Addr.	Command	Notes
0001	Point Dispense Setup - Dispense Time: 0.50 sec - Tail Time: 0.25 sec	Sets the dispensing time for all dots to 0.5 seconds. Sets the waiting time, after dispensing a dot, to 0.25 seconds.
0002	Dispense End Setup - H. Speed: 75 mm/sec - L. Speed: 15 mm/sec - L. Length: 10 mm	Programs the robot to rise, after dispensing. The tip will rise 10 mm (L. Length) at 15 mm/sec (L. Speed) then continues rising at 75 mm/sec (H. Speed) to the Z Clearance height.
0003	Z Clearance - 20 mm - Relative	Sets the Z Clearance value to 20 mm relative to the point location. The maximum height the tip will rise after dispensing is 20 mm above the Dot.
0004	Dummy Point (180, 20, 25)	Registers a 'Dummy' point at: X: 180 mm, Y: 20 mm, Z: 25 mm The tip will move to this XYZ location, but will do nothing. This point is just above the first part in the fixture.
0005	Set INPUT / OUTPUT - Output - Port #: 1 - Status: 1	Closes output signal # 1. Output is turned 'on.'

Addr.	Command	Notes
0006	WAIT POINT - Time: 0.25 sec	Wait for 0.25 seconds
0007	Set INPUT / OUTPUT - Output - Port #: 1 - Status: 0	Open output signal # 1. Output is turned 'off.'
0008	Set INPUT / OUTPUT - Input - Port #: 1 - Status: 0 - GOTO Addr: 12	Check the status of input signal # 1. If the input signal is closed (pin #1 is connected to ground / pin 13), the robot will go to address #0012. If input signal #1 is open (pin #1 is not connected to ground), the program will continue at address #0009
0009	Wait Point - Time: 0.20 seconds	Wait for 0.20 seconds
0010	LOOP ADDRESS - Count: 10 - Address: 8	Repeat instructions 0008 – 0009 (10) times. (10) times a wait time of 0.20 seconds = 2.00 seconds.
0011	GOTO Addr. 0013	If, after 2.0 seconds, the input signal never closed, GOTO address #0013 (Skip the dot dispensing).
0012	Dispense Dot (180,20,35)	Dispenses a dot at X: 180 mm, Y: 20 mm, Z: 35 mm (Dot on the first part in the fixture)
0013	Step & Repeat Y - Columns: 4 - Rows: 3 - X Offset: 25 mm - Y Offset: 30 mm - Start Address: 4 - 'S' Path	Registers the Step & Repeat instruction. The robot will repeat addresses 0004 – 0011 to complete a matrix of 4x3 (12) parts. The distance between parts is 25 mm in the X-axis and 30 mm in the Y-axis. The robot will follow an 'S' Path, through the parts.
0014	End Program	Ends the program. Returns the tip to the home position.

SECTION 7: Error Messages and Specifications

1. Error Messages

1.1 Point Closed Error

This message occurs when two adjacent line or arc points are registered at exactly the same XYZ location.

Resolution: Do not register two line points one after the other at exactly the same XYZ location.

1.2 Need Line Start Point

An attempt was made to register a Line Passing point, an Arc point or a Line End point without first registering a Line Start point.

Resolution: Register a Line Start point before registering a Line Passing point, Arc point or a Line End point.

1.3 Need Step & Repeat

The Expand Step & Repeat command was given but there is no Step & Repeat instruction currently in the display.

Resolution: Select the Step & Repeat function you want to expand before selecting Expand Step & Repeat.

1.4 Unlock Program

An attempt was made to edit a program in Teach mode, which is locked. The program cannot be edited until it is unlocked.

Resolution: Unlock the program in **F2 (Menu 1) → Utility Menu → Lock Program.**

1.5 Address Over Memory

An attempt was made to copy data but the copy would exceed the maximum memory address.

Resolution: Reduce the data to be copied.

1.6 Move Over Memory

An attempt was made to move data but the move would exceed the maximum memory address.

Resolution: Reduce the data to be moved.

1.7 System Error

This message indicates a problem with the CF Memory card.

Resolution: Please contact your dealer.

Note: When an error occurs, it will be displayed on the Teach Pendant. If the Teach Pendant is not connected to the robot, you will first have to turn off the robot, then connect the Teach Pendant to the robot for it to properly function.

2. I/O Specifications

2.1 Dispenser Connector:

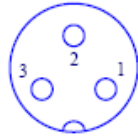

<i>Pin #</i>	<i>Description</i>
1	SIGNAL +
2	SIGNAL -
3	GROUND

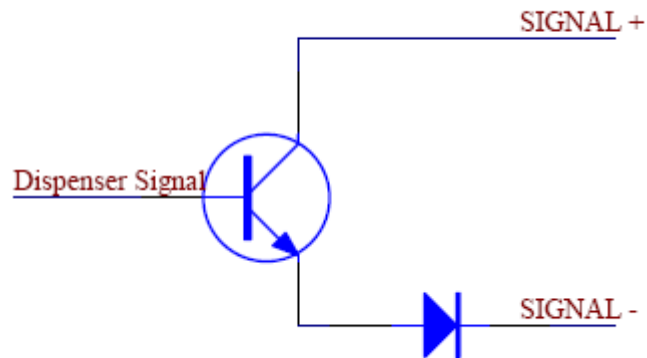

Notes:

1. The MAXIMUM Voltage: 12 VDC
2. The MAXIMUM Current: 200 mA

2.2 Ext. Control Connector:

The pin assignments for the external control connector are as follows:

<i>Pin #</i>	<i>Description</i>
1	Start Signal
2	Start Signal
3	Door Switch (COM)
4	Door Switch (NC)
5	Door Switch (NO)
6	Emergency Stop
7	Emergency Stop



2.3 Output Signals

Pin #	Description
14	OUT #1
15	OUT #2
16	OUT #3
17	OUT #4
18	OUT #5
19	OUT #6
20	OUT #7
21	OUT #8
22	Reserve
23	Reserve
24	+24V
25	+24V

Output Type: Photo-coupler

Output Power:

- F4200N output signals are able to provide a maximum of 24 volts.
- F4200N output signals are able to provide a maximum of 250 milliamps per pin.

Function:

- When the output signal is closed, the circuit between the output pin (#14 - #21) and the +24 Volt power supply (# 24 & #25) is closed.
- The output pins #14 - #21 are already grounded through the robots internal power supply.
- Pins #24 & #25 are the same. They are connected to the +24 volt power supply.

IMPORTANT NOTES:

1. Output signals should be used only to drive external relays. Do not power external devices directly through output signals. Electrical noise will damage the output signal relay.
2. If an inductive load (such as a relay) is connected to an output signal, be sure to install a diode as shown to prevent damage to the output photocoupler:

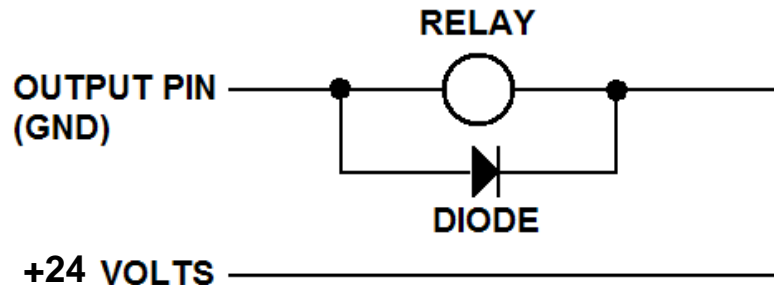

2.4 Input Signals

<i>Pin #</i>	<i>Description</i>
1	IN # 1
2	IN # 2
3	IN # 3
4	IN # 4
5	IN # 5
6	IN # 6
7	IN # 7
8	IN # 8
9	Reserve
10	Reserve
11	GND
12	GND
13	GND

Notes:

1. To close an input signal, short the circuit between the input pin (1 – 8) and a GND(ground) pin (pins #11 - 13).
2. Input signals are powered by the robot's internal power supply: 24 volts, maximum 2.5 mA
3. Check the status of an input signal using the SET I/O command (see **SECTION 5:1.15 - Set I/O**). When the input pin (pin 1 – 8) is connected to a GND pin (pin #11 - #13), the value of the input is 0.

2.5 Input / Output Schematic

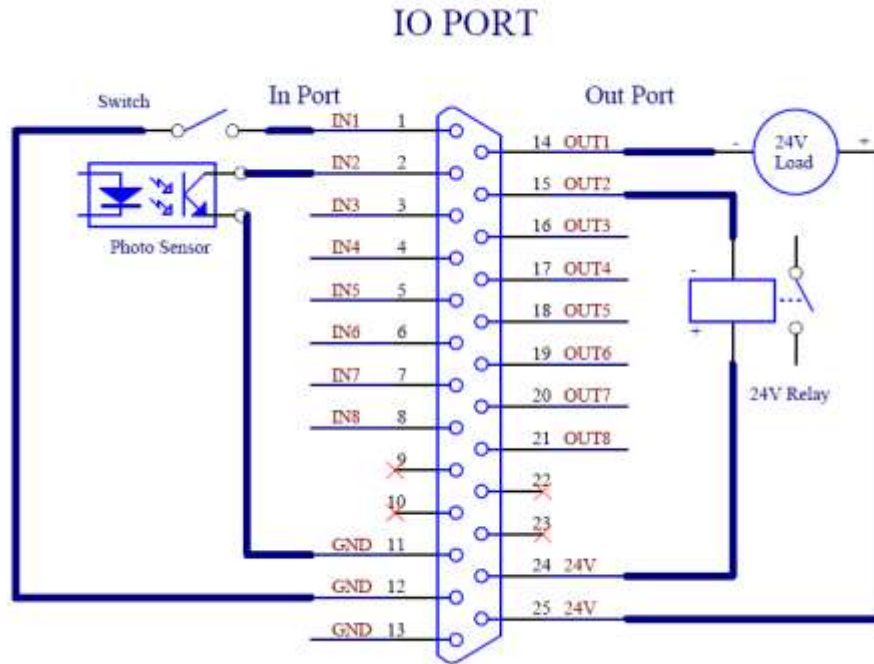

2.6 Input / Output Power Specifications

F4200N		
	Inputs (Internal Power Supply)	Outputs (Internal Power Supply)
MAXIMUM Voltage	24 VDC	24 VDC
MAXIMUM Current	2.5 mA	250 mA

2.7 Robot External I/O Card

The F4200N robot has an optional accessory I/O Card (P/N: **A113005103-C**) which can be used to power external devices for longer periods of time.

Please contact Fisnar for more details.

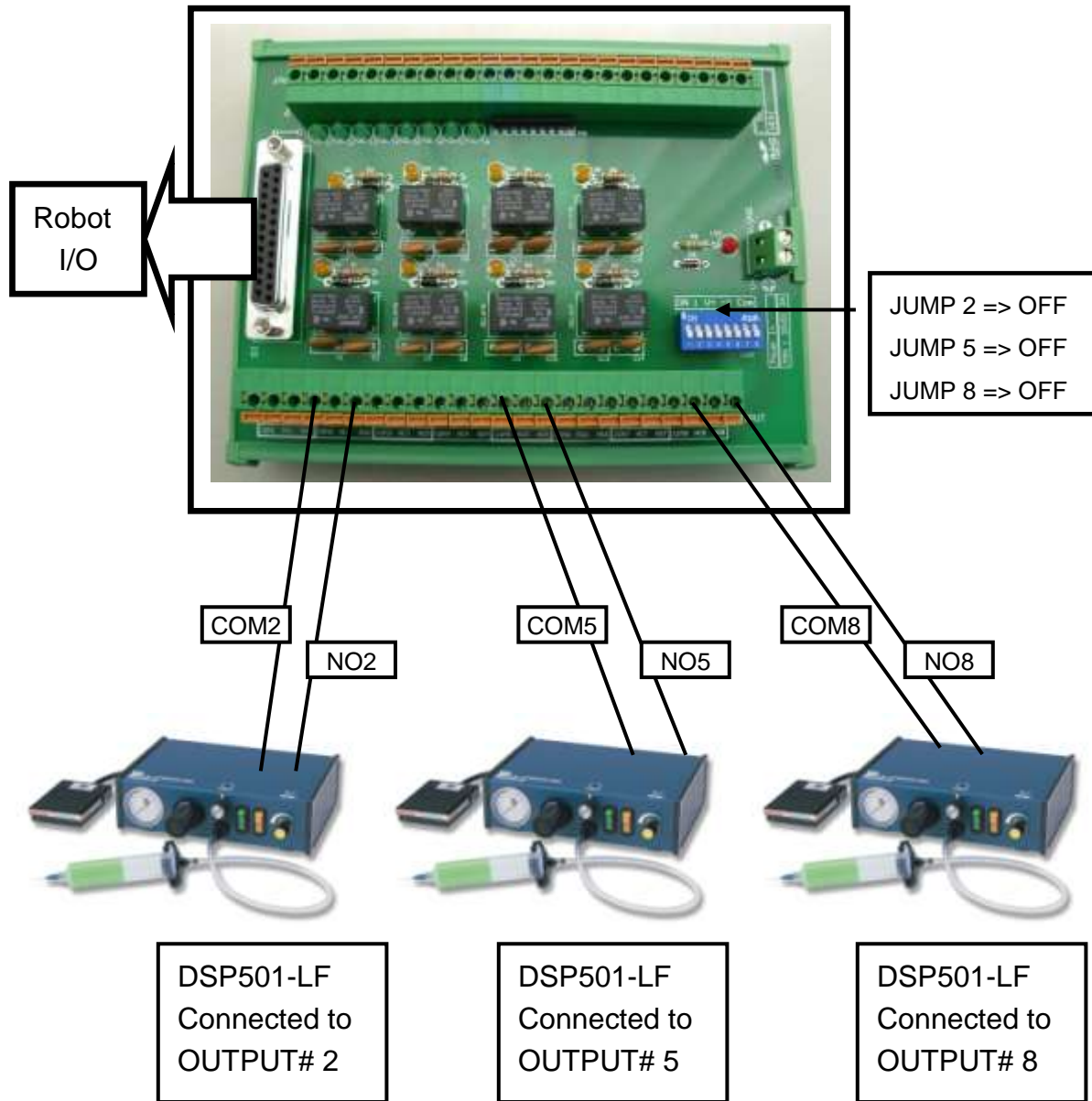

3. System Specifications

F4200N	
Working Area X / Y / Z (mm)	200 / 200 / 50
Load Worktable / Tool	3.0kg / 1.0kg
Maximum Speed X&Y / Z (mm/sec)	500 / 200
Repeatability	+/- 0.02mm/ Axis
Resolution	0.001mm/Axis
Data Memory capacity	4000 points/program
	100 programs
Drive System /Stepping Motor	3-Phase Micro Stepping Motors
Motion Control	PTP & CP
Teaching Method	Teach Pendant
I/O Signals	8 Inputs / 8 Outputs
External Interface	USB / RS232
Power Supply	Auto-switching:
	AC95-132V 200W
	AC180-250V 200W
Dimensions	327 x 500 x 450
WxDxH (mm)	
Weight	33.8lbs. 14.9kg

4. Machine Dimensions

4.1 F4200N Dimensions

UNIT: millimeters (mm)

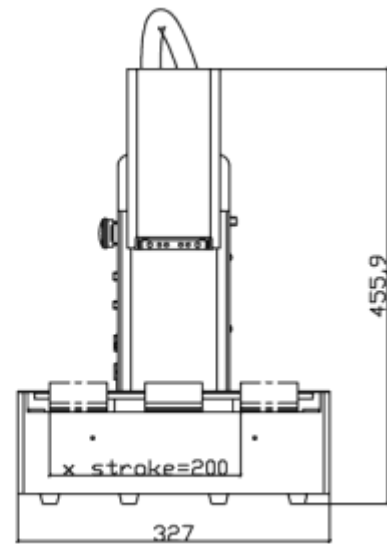
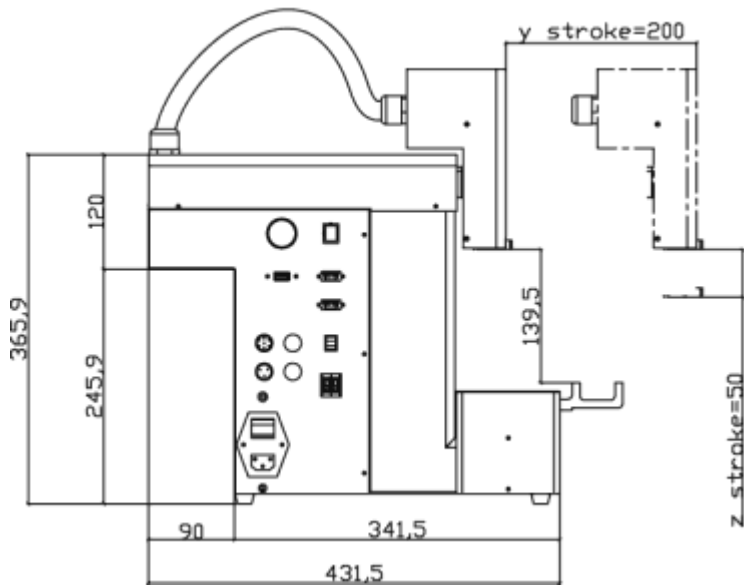
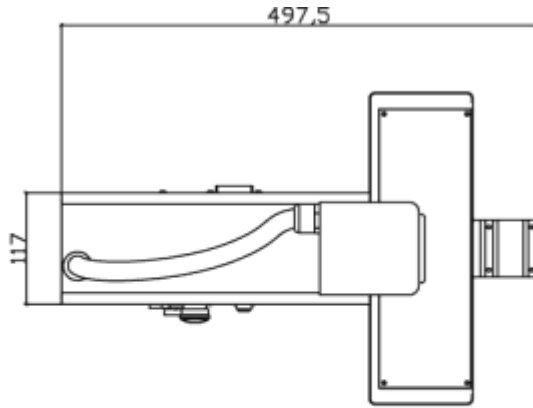

4.2 Work Table Dimensions

Work Table (mm)

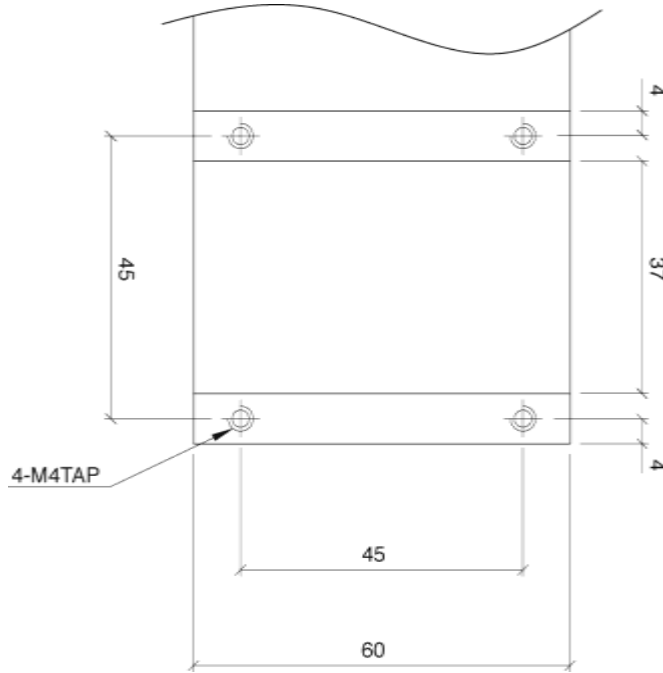

Z-Axis Plate (mm)

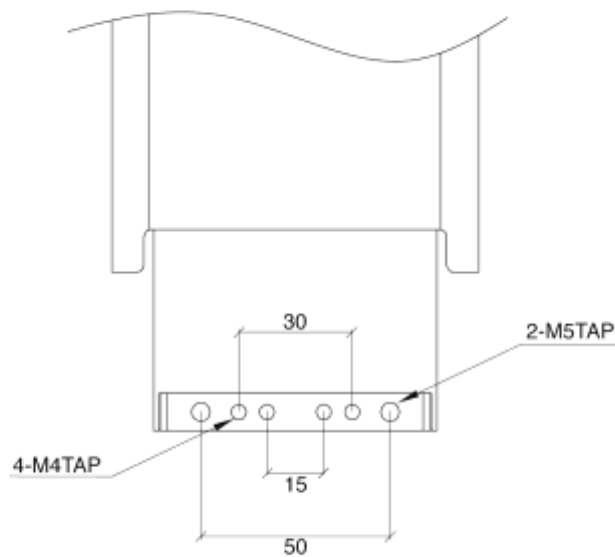

SECTION 8: Maintenance and Periodic Inspection

1. Check Cycles and Methods

1.1 General Consideration

It is essential to correctly and periodically inspect and maintain the robot to prevent unexpected failures or malfunctions, thus ensuring safe operation and lengthening the machine's life.

The outside parts of the machine should be kept clean. Use vacuum cleaner or soft cloth to clean the machine. Do not use compressed air or chemical products to clean the machine, as they can damage the internal cables, timing belts and other components of the unit.

Use only the greasing materials recommended by the manufacturer of the machine.

1.2 Check Cycles and Points

The check cycles of the machine are classified in the following categories:

- Daily check
- Weekly check
- Check after every 3 months of operation
- Check after every 3 years of operation

The checkpoints are as follows:

CHECK POINT	CHECK CYCLE			
	Daily	Weekly	Every 3 months	Every 3 years
Tilt or deviation of machine	X			
Status of cables and hoses	X			
Appearance	X			
Stability on the work bench	X			
Motor running condition		X		
Motions, connections and joints			X	
Unfastened / loose bolts and screws			X	
Internal wires and connectors			X	
Accuracy and precision			X	
Ball screw assembly, LM guide, slide guide			X	
Overhaul				X

1.3 Check Methods

Check point	Check action (See if)	Corrective action
Tilt or deviation of machine	<ul style="list-style-type: none"> Robot working position is tilted or inclined 	<ul style="list-style-type: none"> Set the machine in a proper vertical position
Status of cables and hoses	<ul style="list-style-type: none"> Electrical cables and pneumatic hoses are excessively twisted, bent, or squeezed Air leakage between pneumatic hoses and fittings 	<ul style="list-style-type: none"> Remove the causes of twisting, bending, or squeezing Cut away the damaged parts of hoses and make connections
Appearance	<ul style="list-style-type: none"> Damage on the robot's head from clashes during operation 	<ul style="list-style-type: none"> Pay attention to working area of robot and remove any obstacle
Stability on work bench	<ul style="list-style-type: none"> The robot is too close to the edge of the work table 	<ul style="list-style-type: none"> Rearrange the position of the robot on the table Remove sources causing table vibration
Motor running condition	<ul style="list-style-type: none"> Infiltration of grease Performance degradation due to overload 	<ul style="list-style-type: none"> Replace motor (see agent)
Motions, connections, and joints	<ul style="list-style-type: none"> The axes are not moving smoothly Noises, vibrations, and / or shakes 	<ul style="list-style-type: none"> Grease up Reset and adjust gains (contact agent for setting)
Unfastened / loose bolts and screws	<ul style="list-style-type: none"> Loose or broken bolts and nuts 	<ul style="list-style-type: none"> Tighten loose bolts and nuts. Take corrective action to remove the cause
Internal wires and connectors	<ul style="list-style-type: none"> Stripped or damaged external cover or shield on cable and/or connectors 	<ul style="list-style-type: none"> Replace the damaged cables or connectors with new ones (see agent)
Accuracy and precision	<ul style="list-style-type: none"> Z run out over X or Y larger than 0.2mm Wear on timing belt 	<ul style="list-style-type: none"> Contact agent Replace timing belt (see agent)
Ball screw (worm gear) assembly, LM guide, slide guide	<ul style="list-style-type: none"> Lack of grease on shaft, LM guide and / or slide guide surfaces Deflection of the shaft 	<ul style="list-style-type: none"> Apply grease on grease-hole of worm gear, LM guide, and slide guide surfaces (see section 9:2) Replace the shaft (contact agent)
Overhaul	<ul style="list-style-type: none"> Diagnose the whole system and make decision for the overhaul 	<ul style="list-style-type: none"> Contact agent

2. Greasing Procedure

2.1 Grease Type and Greasing Interval

- Grease type: 30 – 100 centistokes (recommended: THK AFA 70G)
- Greasing period: every 6 months

2.2 Accessing Parts to be Greased

- Unscrew the bolts shown with arrows in the following pictures and remove the covers.
- Apply grease into the grease hole of ball screw (worm gear) and also thinly to the surfaces of LM guide and slide guide.
- Put back the covers and screw in the bolts.

X-Axis

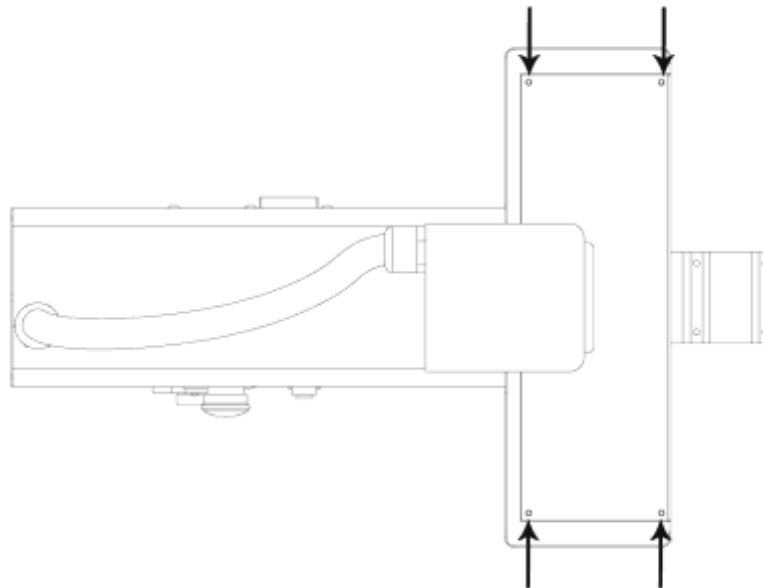

Y-Axis

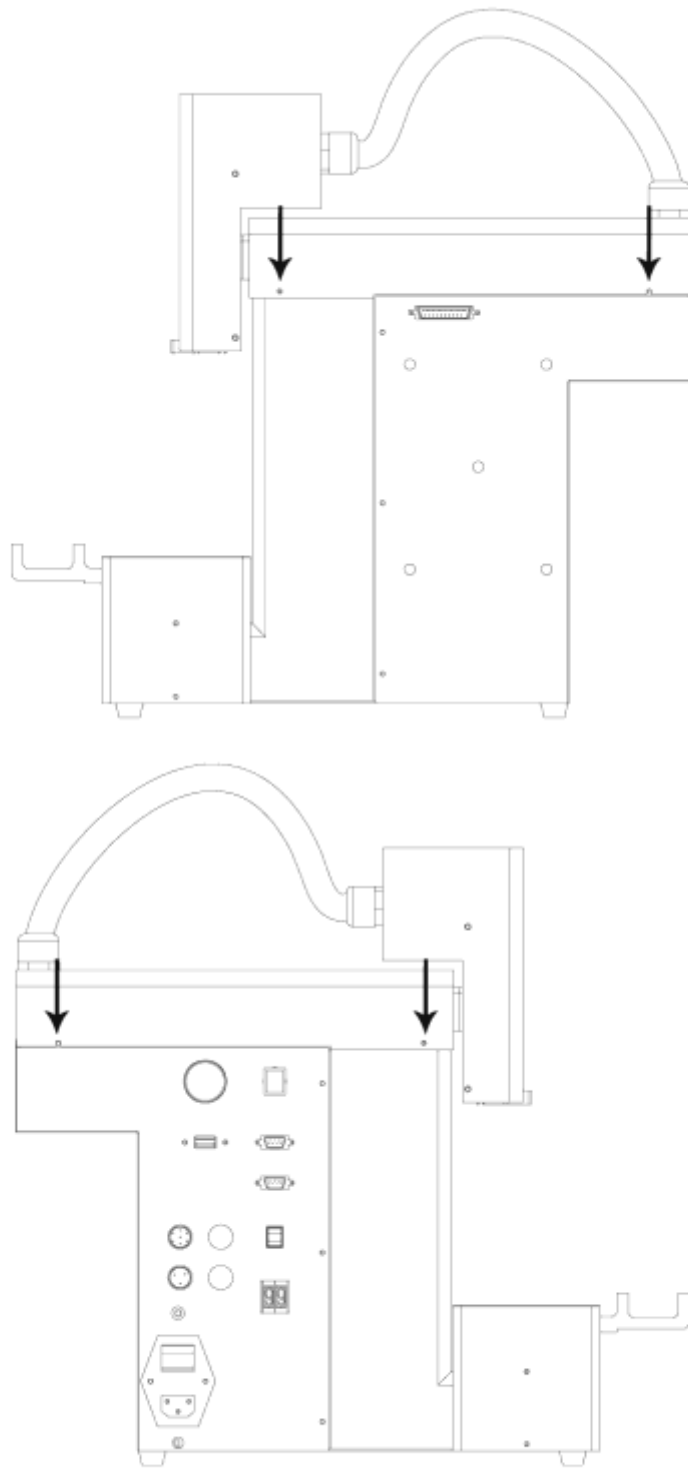

Z-Axis

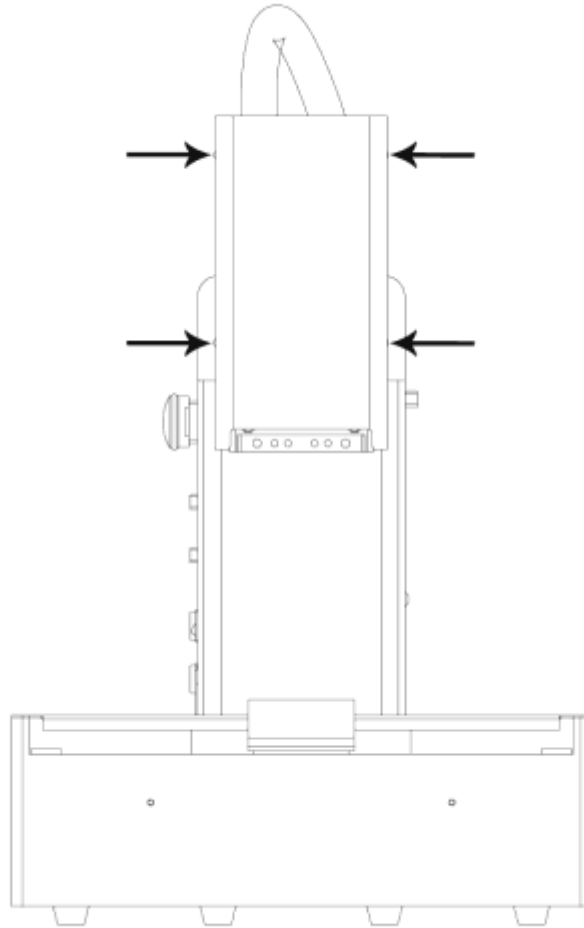

THIS PAGE INTENTIONALLY LEFT BLANK



15 Corporate Drive, Suite E - Wayne - NJ 07470
Tel: (973) 646-5044 E-mail: info@fisnar.com
www.fisnar.com

